



## KL-0039-..Silent Blocks

### Universal Silent Block/Joint Bearing Tool Series



**Operating instructions** EN  
 ⚠ Read and understand before use!

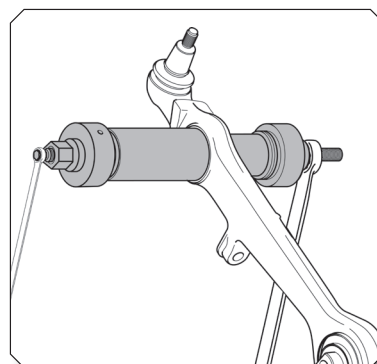

[www.gedore-automotive.com](http://www.gedore-automotive.com)

**GEDORE Automotive GmbH**

Breslauer Straße 41  
 78166 - Donaueschingen  
 Postfach 1329  
 78154 Donaueschingen - GERMANY

☎ +49 (0) 771 / 8 32 23-0  
 ☎ +49 (0) 771 / 8 32 23-90  
 ✉ info.gam@gedore.com  
 🌐 gedore-automotive.com

**GEDORE TOOLS, INC.**

Only for USA, Canada & Mexico / Sólo para EE.UU., Canadá y México  
 Seulement pour les USA, le Canada et le Mexique  
 7187 Bryhawke Circle, Suite 700  
 North Charleston, SC 29418, USA

☎ +1-843 / 225 50 15  
 ☎ +1-843 / 225 50 20  
 ✉ info@gedoretools.com  
 🌐 gedore.com

Version 9 - 01/2022



**ENGLISH**

**EN**

## Manufacturer's address

**GEDORE Automotive GmbH**

Breslauer Straße 41 // 78166 Donaueschingen - GERMANY

+49 (0)771/83223-71 // [info.gam@gedore.com](mailto:info.gam@gedore.com)

## Imprint

In the course of improvement and adaptation to the state of the art, we reserve the right to make changes with regard to appearance, dimensions, weights and properties, and performance.

This does not imply any claim to correction or subsequent delivery of already delivered products. Deletions can be made at any time without any legal claim arising.

Instructions for use and safety are not binding. They never substitute for any legal or trade association regulations.

We do not accept any liability for printing errors.

Any reproduction, in whole or in part, requires the prior written consent of **GEDORE Automotive GmbH**.

All rights reserved worldwide. © Copyright by **GEDORE Automotive GmbH**, Donaueschingen (GERMANY)

We refer to our general terms and conditions which  
can be found in the imprint at:

**[www.gedore-automotive.com](http://www.gedore-automotive.com)**



## Contents

<b>1. READ AND UNDERSTAND FOR YOUR SAFETY</b> .....	<b>4</b>
1.1 Target group.....	4
1.2 Obligations of the owner.....	4
1.3 Intended use .....	4
1.4 Reasonably foreseeable misuse .....	4
1.5 Personal protective equipment.....	5
1.6 Labelling of the warnings .....	5
1.7 Basic warnings .....	5
1.8 Basic safety instructions .....	6
1.9 Work environment.....	7
1.10 Emissions .....	7
1.11 Maintenance.....	7
1.12 Troubleshooting .....	7
<b>2. PRODUCT DESCRIPTION</b> .....	<b>8</b>
2.1 KL-0039-.. Silent block/joint bearing tool series .....	8
2.2 Scope of delivery / Single parts overview / Specifications .....	10
<b>3. PREPARATION</b> .....	<b>13</b>
3.1 Checking the scope of delivery.....	13
3.2 Assembling drive parts .....	13
3.3 Preparing the vehicle .....	14
3.4 Determining pressure sleeve and support sleeve .....	14
<b>4. TYPICAL APPLICATIONS</b> .....	<b>15</b>
4.1 Pressing out and in by means of <u>pull spindle</u> .....	16
Pressing out silent blocks.....	16
Pressing in silent blocks.....	17
4.2 Pressing out and in by means of <u>press frame</u> .....	18
Pressing out silent blocks.....	18
Pressing in silent blocks.....	19
4.3 Pressing out and in by means of <u>stand press</u> .....	20
Pressing out silent blocks.....	20
Pressing in silent blocks.....	21
<b>5. CARE AND STORAGE</b> .....	<b>22</b>
<b>6. REPAIR</b> .....	<b>22</b>
<b>7. SILENT BLOCK/JOINT BEARING TOOL</b> .....	<b>22</b>
<b>8. ENVIRONMENTALLY FRIENDLY DISPOSAL</b> .....	<b>23</b>

EN

## 1. READ AND UNDERSTAND FOR YOUR SAFETY



Read and understand these operating instructions **before using** the silent block/joint bearing tool, and observe all safety and warning instructions! Misuse can result in **DEATH** or **SEVERE INJURIES**! These operating instructions are an integral part of the silent block/joint bearing tool. Keep them at a safe place for future reference, and always pass them on to subsequent users of the silent block/joint bearing tool! The silent block/joint bearing tool complies with the recognised rules of technology as well as the relevant safety regulations!

### 1.1 Target group

These operating instructions are **exclusively** intended for skilled personnel in specialised motor vehicle workshops!

The silent block/joint bearing tool **may only be** used by skilled personnel in specialised motor vehicle workshops who are familiar with the- regulations on work safety and accident prevention!

▶ **Never** allow unauthorised, inexperienced persons, minors and children, or persons with limited physical, sensory, and mental abilities to use the silent block/joint bearing tool!

### 1.2 Obligations of the owner

Pursuant to the German Ordinance on Industrial Safety and Health (*BetrSichV*), employers are obliged to provide their employees with safe work equipment in accordance with the recognised rules of technology and the relevant safety regulations!

▶ The owner of the silent block/joint bearing tool **must** ensure that **only** trained personnel in specialised vehicle workshops use the silent block tool!

▶ The owner of the silent block/joint bearing tool **must** ensure that the instructions for use are available to the user and that the user has completely read and understood the instructions for use **before** using the silent block/joint bearing tool!

▶ The owner of the silent block/joint bearing tool **must** ensure that the user is familiar with the basic regulations on work safety and accident prevention, and that the personal protective equipment is available to him!

### 1.3 Intended use

**The silent block/joint bearing tool...**

▶ **may only** be used for pressing out and pressing in silent block/joint bearings.

▶ **May only** be used up to the **max. load of the weakest component used!**

▶ **may only** be driven by hand with muscle power together with a manual drive, a manually driven strand press, or a manually operated **GEDORE Automotive** hydraulic cylinder/pump combination with a pressure gauge for safe pressure control!

▶ **may only** be used with **GEDORE Automotive** genuine spare parts and accessories!

▶ **may only** be used in the way described in these operating instructions!

⚠ Any other use can result in **DEATH** or **SEVERE INJURIES** !

### 1.4 Reasonably foreseeable misuse

**The silent block/joint bearing tool...**

▶ **must never** be used for pressing out or in other parts than those intended for it!

▶ **must never** be used together with an impulse or impact screwdriver!

▶ **must never** be used with a machine drive, a machine-operated stand press, or a hydraulic cylinder/pump combination, or any other drive than intended!

▶ **must never** be used for batch processing with many forcing in/out processes within a few minutes!

▶ **must never** be used with a bridged, modified, or removed safety device!

▶ **must never** be modified, converted, or used for other purposes without authorisation!

⚠ Use the silent block/joint bearing tool **always** as intended. Any other use can result in **DEATH** or in **SEVERE INJURIES**!

### 1.5 Personal protective equipment

For your safety, **always** wear personal protective equipment when using the silent block/joint bearing tool! The silent block/joint bearing tool can bring about mechanical hazards, such as crushing, cutting, and shock injuries.



Always wear **EYE PROTECTION** (for example to DIN EN 166, OSHA 29 CFR 1910.133, ANSI Z87) when using the silent block/joint bearing tool to protect yourself against flinging parts or particles!

When using the silent block/joint bearing tool, flinging parts or particles can cause **SEVERE INJURIES** to your **eyes!**



Always wear **PROTECTIVE GLOVES** (for example to DIN EN 388, OSHA 29 CFR 1910.138, ANSI 105) when using the silent block/joint bearing tool to protect yourself against sharp edges and crushing between parts!

When working with the silent block/joint bearing tool, sharp edges and crushing between parts can cause **SEVERE INJURIES** to your **hands!**



Always wear **SAFETY SHOES** (for example to DIN EN ISO 20345, OSHA 29 CFR 1910.136, ANSI Z41) when using the silent block/joint bearing tool to protect yourself against dropping parts!

When working with the silent block/joint bearing tool, falling parts can cause **SEVERE INJURIES** to your **feet and toes!**

### 1.6 Labelling of the warnings

Warnings warn of potential **hazards**. **Always** observe these warnings to avoid **DEATH** or **INJURIES!**

For better differentiation, warnings in these operating instructions are classified as follows:	
Warning sign	Meaning
	Indicates a hazardous situation which, if not avoided, could cause <b>DEATH</b> or <b>SEVERE INJURIES</b> .
	Indicates a hazardous situation which, if not avoided, could cause <b>MODERATE</b> or <b>MINOR INJURIES</b> .
	Indicates a situation which, if not avoided, can cause damage to the tool or an object in its vicinity.
	<b>Note</b> on important information and useful tips.

### 1.7 Basic warnings

#### **⚠ WARNING - Danger to life from MISUSE**

**MISUSE** can cause the silent block/joint bearing tool to slip, break, and thus drop or be hurled about. This can cause **DEATH** or **SEVERE INJURIES!**

- When reading and understanding these operating instructions **before using** the silent block/joint bearing tool, and observe all safety and warning instructions for **safe use!**
- Always** work with the silent block/joint bearing tool in accordance with the basic regulations on work safety and accident prevention!
- Only** use the silent block/joint bearing tool as described in these operating instructions!
- Always** observe the vehicle-specific application procedures in the repair guide of the vehicle manufacturer!
- Never** use the silent block/joint bearing tool if it is damaged or has loose parts or unauthorised modifications!
- Never** use the silent block/joint bearing tool with an impulse or impact wrench!
- Never** use the silent block/joint bearing tool with a machine-operated drive. Drive it **exclusively** by hand with muscle power with a manual drive, or a manually driven stand press or **GEDORE Automotive** hydraulic cylinder/pump combination with pressure gauge for safe pressure control!
- Never** use the silent block/joint bearing tool for batch processing with numerous forcing in/out processes within a few minutes!
- Always** wear your personal protective equipment (*safety goggles, protective gloves, safety shoes*) during work!
- Never** hit the silent block/joint bearing tool with a hammer or anything similar!

## ⚠ WARNING - Danger to life from OVERLOAD

**OVERLOAD** can cause the silent block/joint bearing tool to slip, break, and thus drop or be hurled about. This can cause **DEATH** or **SEVERE INJURIES**!

- ✔ **Never** exceed the **maximum load** of the silent block/joint bearing tool or the individual components!
- ✔ **Never** use the silent block/joint bearing tool if it is damaged, has loose parts, or unauthorised modifications!
- ✔ **Never** use the silent block/joint bearing tool with an impulse or impact wrench!
- ✔ **Never** use the silent block/joint bearing tool with a machine-operated drive. Drive it **exclusively** by hand with muscle power with a manual drive, or a manually driven stand press or **GEDORE Automotive** hydraulic cylinder/pump combination with pressure gauge for safe pressure control!
- ✔ **Never** use the silent block/joint bearing tool for batch processing with numerous forcing in/out processes within a few minutes!
- ✔ **Always** wear your personal protective equipment (*safety goggles, protective gloves, safety shoes*) during work!

## ⚠ WARNING - Danger of injury from FALLING

There is a risk of the silent block/joint bearing tool **DROPPING** during preparation and use; for example, when used overhead. This can cause **SEVERE INJURIES** at the head!

- ✔ Before use, **always** secure the silent block/joint bearing tool against falling off the vehicle or axle, e.g. using the safety retaining belt available as an accessory - **KL-0040-2590** or **KL-0040-2592**!
- ✔ **Always** avoid dropping the silent block/joint bearing tool!
- ✔ **Always** make sure that the silent block/joint bearing tool is securely attached to the vehicle!
- ✔ **Never** leave the silent block/joint bearing tool unattended in loaded condition at the axle!
- ✔ Put down the silent block/joint bearing tool **safely** to prevent it from dropping, for example on a workbench!
- ✔ **Always** carry out necessary preparations of heavy parts with the help of a second specialist!
- ✔ **Always** check the stability of the silent block/joint bearing tool before use!
- ✔ **Always** wear your personal protective equipment (*safety goggles, protective gloves, safety shoes*) during work!

## ATTENTION - Risk of DAMAGE

The vehicle, silent block/joint bearing or support joint, and the silent block/joint bearing tool can be **DAMAGED**.

- ✔ **Always** observe the installation position of the silent block/joint bearing and support joint specified by the vehicle manufacturer!
- ✔ **Always** observe vehicle-specific application procedures in the repair guide of the vehicle manufacturer.
- ✔ **Prior to each use**, check the moving parts and the spindle of the silent block/joint bearing tool for sufficient lubrication. If necessary, lubricate them only with molybdenum disulphide paste (*for example with GEDORE KL-0014-0030*)!
- ✔ **Never** use the silent block/joint bearing tool for batch processing with numerous forcing in/out processes within a few minutes!
- ✔ **Never** clamp the silent block/joint bearing tool in a vice.

## 1.8 Basic safety instructions

For your safety, **always** observe the following safety precautions when using the silent block/joint bearing tool in order to avoid injuries and material damage caused by misuse or unsafe handling.

- ✔ Read and understand these operating instructions **before using** the silent block/joint bearing tool, and observe all safety and warning instructions for **safe use**!
- ✔ **Always** observe the vehicle-specific application procedures in the repair guide of the vehicle manufacturer!
- ✔ **Always** work with the silent block/joint bearing tool in accordance with the basic regulations on work safety and accident prevention!
- ✔ **Never** use the silent block/joint bearing tool when you are tired or under the influence of alcohol, drugs, or medication!
- ✔ **Before each use**, check the silent block/joint bearing tool **carefully** for damage, loose parts, or unauthorised modifications. **Never** use it if you notice any such deficiencies!
- ✔ Use **only genuine GEDORE Automotive** spare parts and accessories!
- ✔ **If necessary**, carry, lift, and position the silent block/joint bearing tool with the help of a second specialist due to its weight!
- ✔ **Before using** the silent block/joint bearing tool, make sure that **no** unauthorised persons are in the immediate environment!
- ✔ **Always** observe the **max. loading capacity** when using the silent block/joint bearing tool and the individual components, and **never** exceed it!
- ✔ **Never** stand in axial extension of the silent block/joint bearing tool when it is under load!

- ✔ **Never** use the silent block/joint bearing tool with an unauthorised drive. Drive it **only** with an approved drive!
- ✔ **Always** wear your personal protective equipment (*safety goggles, protective gloves, safety shoes*) during work!
- ✔ Interrupt your work **immediately** if you are unsure about using the silent block/joint bearing tool, and contact **GEDORE Automotive GmbH if necessary!**
- ✔ For safety reasons, ensure that a damaged silent block/joint bearing tool is no longer used! Professional inspection and repair may only be carried out by specially trained personnel from **GEDORE Automotive GmbH!**
- ✔ **Always** use the silent block/joint bearing tool as intended. Non-compliance will invalidate any warranty claim and may significantly reduce its durability!

### 1.9 Work environment

For your safety, **only** use the silent block/joint bearing tool in a safe working environment.

- ✔ The workplace **must** be clean and tidy.
- ✔ The workplace **must** be sufficiently large and illuminated.
- ✔ The workplace **must** be on a solid and non-skidding floor.
- ✔ The workplace **must** be safeguarded against access of unauthorised persons.
- ✔ The workplace **must** have a room temperature between -10°C and +40°C.

### 1.10 Emissions

Molybdenum disulphide paste and hydraulic oil can drip or escape when using the silent block/joint bearing tool and thus pose a hazard to the environment.

- ✔ **Immediately** remove leaking hydraulic oil as well as excess molybdenum disulphide paste (using oil binding agents or a rag, for example).
- ✔ In case of skin contact with hydraulic oil, clean the affected area **immediately** with degreasing soap and water.
- ✔ Dispose of pollutants such as hydraulic oil and molybdenum disulphide paste in an **environmentally friendly** manner.
- ✔ Safety data sheets *in accordance with Regulation (EC) No. 1907/2006*, for hydraulic oil (**Alsus Hyd HLP 32**) as well as for molybdenum disulphide paste (**MOLYKOTE(R) G-N PLUS PASTE**) can be found on the manufacturer's site on the Internet (**World Wide Web**) or, if required, contact **GEDORE Automotive GmbH**.

### 1.11 Maintenance

Perform maintenance on the silent block/joint bearing tool **at regular intervals** and **only** when the tool is tension-free/depressurised! Poor and improper maintenance can damage the silent block/joint bearing tool, thus causing **DEATH** or **SEVERE INJURIES!**

#### Prior to each use:

- ✔ **Prior to each use**, check the silent block/joint bearing tool **carefully** for damage, loose parts, or unauthorised modifications!
- ✔ **Prior to each use** of the silent block/joint bearing tool, check the spindle for contamination and damage. If necessary, clean it, and subsequently lubricate it **only** with molybdenum disulphide paste! (For example, **GEDORE Automotive** molybdenum disulphide paste - **KL-0014-0030**)

#### Every 6 months:

- ✔ Clean and lubricate the spindle on the silent block/joint bearing tool **at least every 6 months** and **only** with molybdenum disulphide paste! (For example, **GEDORE Automotive** molybdenum disulphide paste - **KL-0014-0030**)

#### Recommended: Every 24 months:

- ✔ Have the silent block/joint bearing tool professionally checked **every 24 months** by authorised specialists from **GEDORE Automotive GmbH!**

### 1.12 Troubleshooting

Troubleshoot problems with the silent block/joint bearing tool **always** when the tool is tension-free/depressurised!

**Problem:** Clamping nut on the spindle of the silent block/joint bearing tool is sluggish. (*Mechanical drive*)

**Reason:** The spindle is contaminated or insufficiently lubricated, or wrong lubricant was used.

**Remedy:** Clean the spindle, check it for damage, and lubricate it **only** with molybdenum disulphide paste. (For example, **GEDORE Automotive** molybdenum disulphide paste - **KL-0014-0030**)

**Problem:** Hydraulic oil escapes from the hydraulic coupling between hydraulic cylinder and hand pump.

**Reason:** Hydraulic coupling contaminated or loose.

**Remedy:** Clean and retighten the hydraulic coupling. Top up lacking hydraulic oil (**HLP 32**) at the hand pump.

## 2. PRODUCT DESCRIPTION

### 2.1 - KL-0039-.. Silent block/joint bearing tool series

The modular system of the **KL-0039-..Silent block/joint bearing tool series** enables the forcing out and in of silent blocks/joint bearings and support joints in **three** different ways, for example...

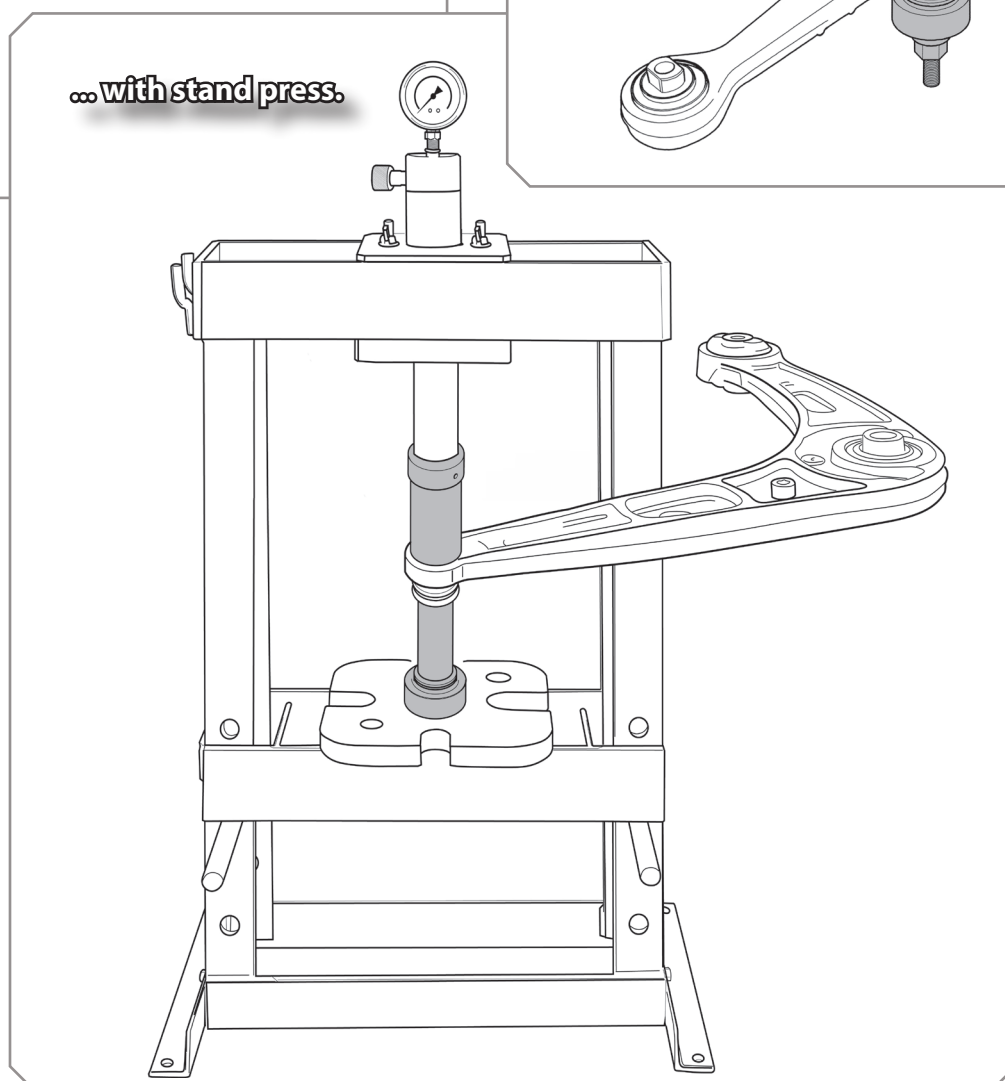
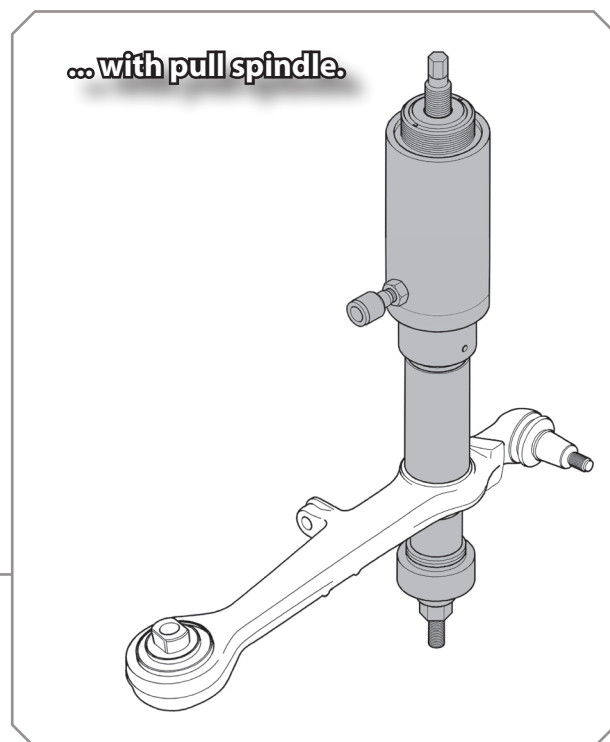
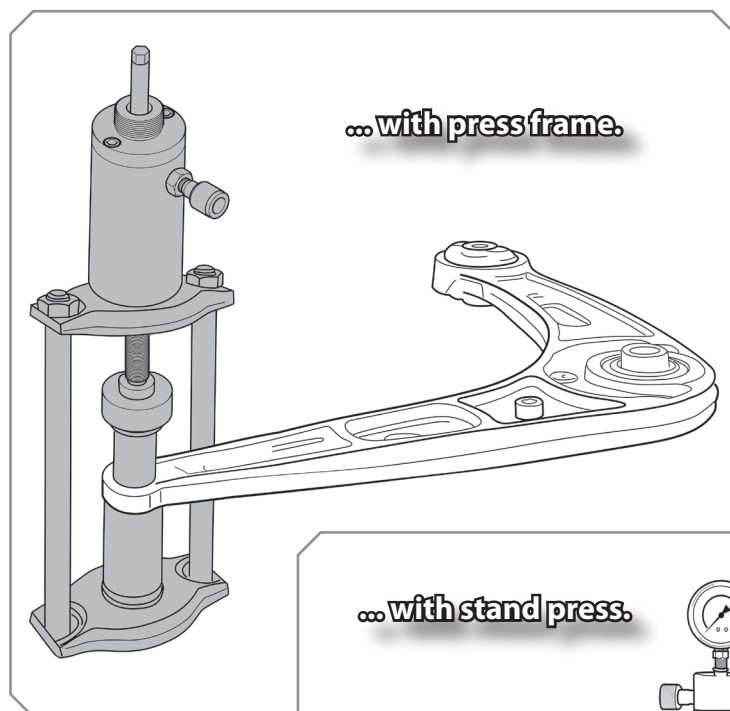



Depending on the chosen method, the components required for this must be assembled accordingly, for example ...

...with pull spindle.

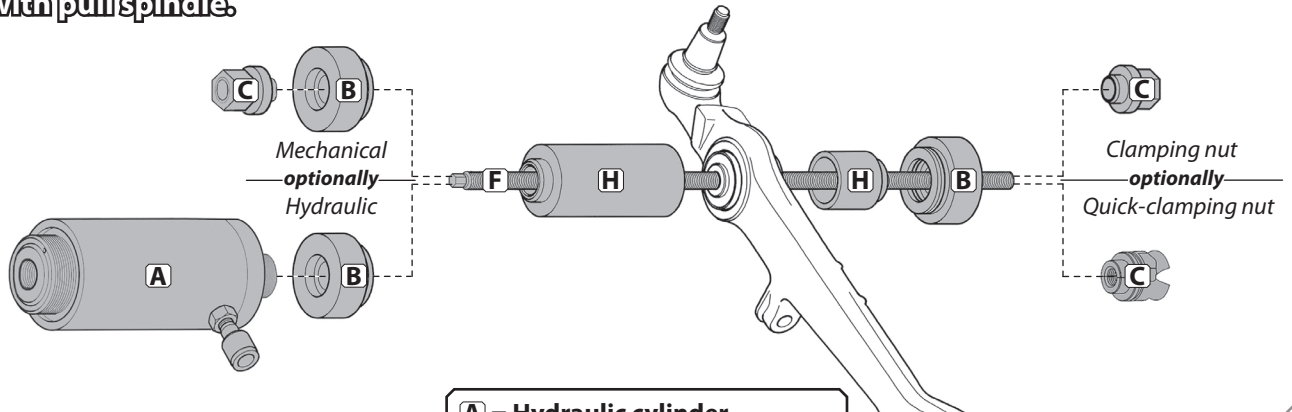

- A** = Hydraulic cylinder
- B** = Retaining adapter
- C** = Clamping nut
- D** = Mechanical drive
- E** = Guide bolt
- F** = Pull spindle
- G** = Thrust spindle
- H** = Pressure/supporting sleeve
- J** = Press frame

...with press frame.

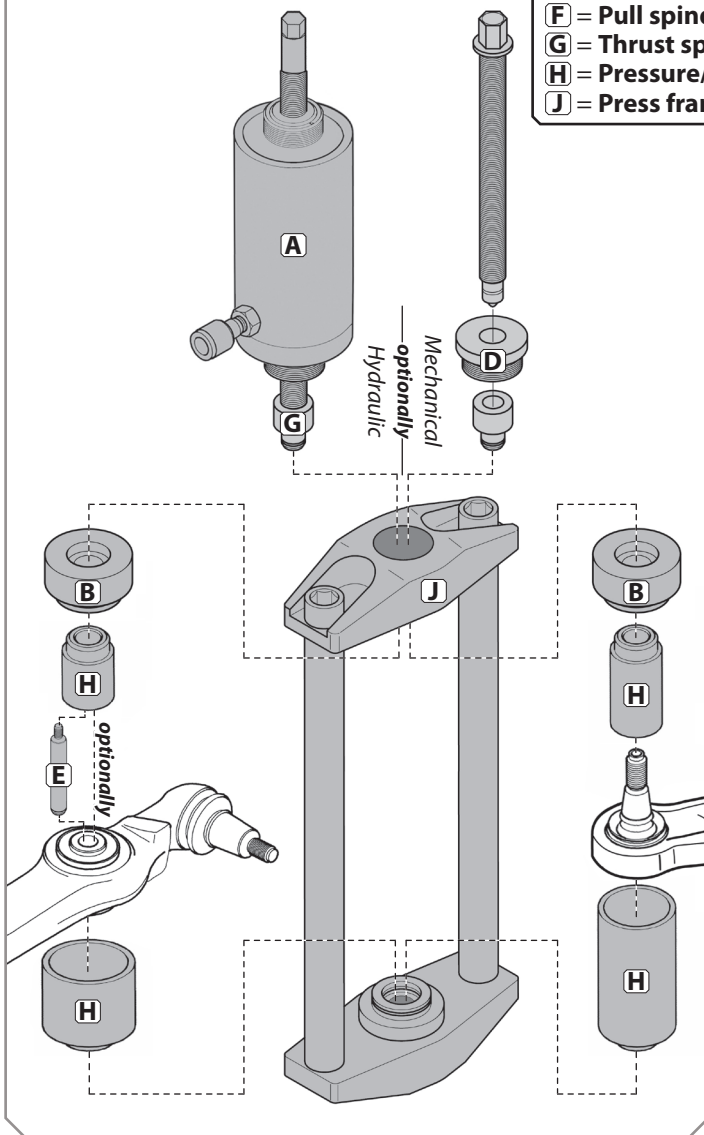

...with stand press.

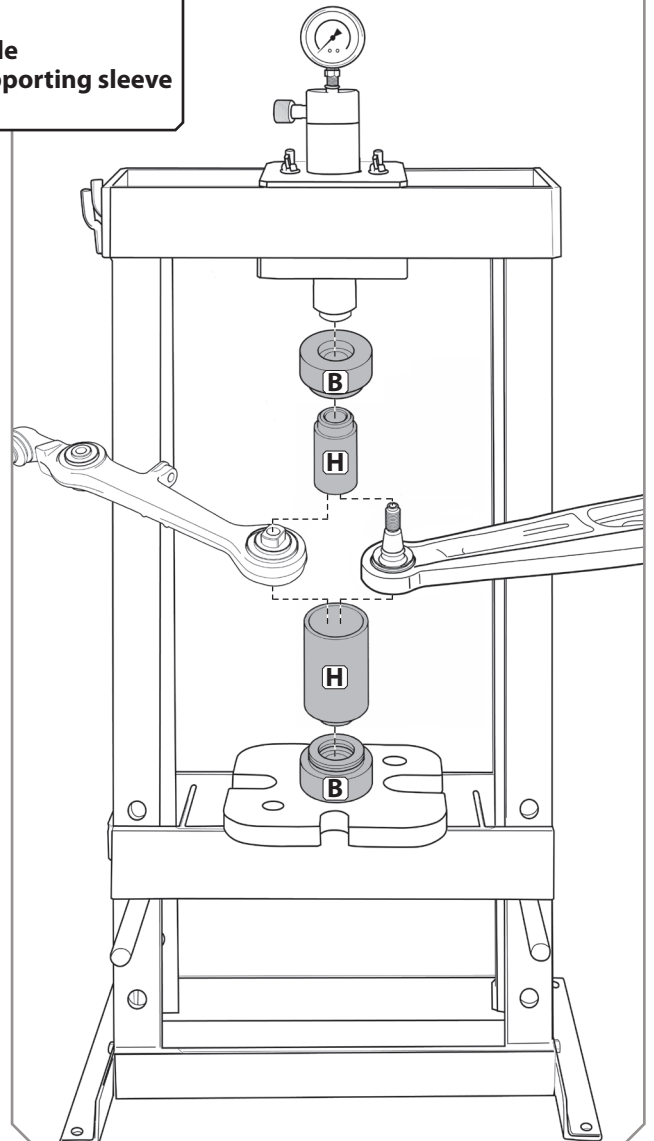

## 2.2 Scope of delivery / Single parts overview / Specifications

① This table shows the basic components of the **KL-0039-...Silent block/joint bearing series**.

Other accessories see GEDORE Automotive catalogue!

### Silent block/joint bearing tool sets

		KL-0039-1161 E	KL-0039-190 EA	KL-0039-413 K	KL-0039-160 E	KL-0039-160 I	KL-0039-170 E	KL-0039-170 I
<b>Foam insert...</b>								
KL-4999-1310 - Foam insert	-		•					
KL-4999-1311 - Foam insert	-						•	
KL-4999-1312 - Foam insert	-				•			
KL-4999-1318 - Foam insert	-	•						
<b>Plastic case...</b>								
KL-4999-4139 - Plastic case	-			•				
KL-4999-1391 - Plastic case	-	Accessories						
<b>Molybdenum disulphide paste...</b>								
KL-0014-0030 - Molybdenum disulphide paste	-		•	•				
<b>Hydraulic cylinder...</b>								
KL-0040-2500 - Hydraulic cylinder (max. 17t)	A							
<b>Retaining adapter...</b>								
KL-0039-1002 - Retaining adapter for clamping nut + thrust spindle	B1		•	•				
KL-0039-1003 - Retaining adapter for hydraulic cylinder	B2		•					
KL-0039-1011 - Retaining adapter for mechanical spindle	B3		•	•				
<b>Clamping nut...</b>								
KL-0039-1910-2 - Clamping nut M10	C1		• 2x	• 2x				
KL-0039-1912-2 - Clamping nut M12	C2		• 2x	• 2x				
KL-0039-1914-2 - Clamping nut M14	C3		• 2x	• 2x				
KL-0039-1916-2 - Clamping nut M16	C4			• 2x				
KL-0040-3009 - Clamping nut M20	C5		•					
KL-0039-2110-2 - Quick-clamping nut M10	C6							
KL-0039-2112-2 - Quick-clamping nut M12	C7							
KL-0039-2114-2 - Quick-clamping nut M14	C8							
KL-0039-2116-2 - Quick-clamping nut M16	C9							
KL-0039-2120-2 - Quick-clamping nut M20	C10							
<b>Mechanical drive...</b>								
KL-0174-831 - Mechanical drive set	D		•	•				
<b>Guide bolt...</b>								
KL-0039-1610 - Guide bolt, 10mm dia., short	E1					•		
KL-0039-1612 - Guide bolt, 12mm dia., short	E2					•		
KL-0039-1614 - Guide bolt, 14mm dia., short	E3					•		
KL-0039-1616 - Guide bolt, 16mm dia., short	E4					•		
KL-0039-1710 - Guide bolt, 10mm dia., long	E5							•
KL-0039-1712 - Guide bolt, 12mm dia., long	E6							•
KL-0039-1714 - Guide bolt, 14mm dia., long	E7							•
KL-0039-1716 - Guide bolt, 16mm dia., long	E8							•
<b>Pull spindle...</b>								
KL-0039-2010-1 - Pull spindle M10, mechanical (max. 5t)	F1		•	•				
KL-0039-2012-1 - Pull spindle M12, mechanical (max. 7t)	F2		•	•				
KL-0039-2014-1 - Pull spindle M14, mechanical (max. 9t)	F3			•				
KL-0039-2016-1 - Pull spindle M16, mechanical (max. 13t)	F4			•				
KL-0039-2030 - Pull spindle M20, mechanical (max. 20t)	F5		•					
KL-0039-1910-1 - Pull spindle M10, hydraulic (max. 5t)	F6							
KL-0039-1912-1 - Pull spindle M12, hydraulic (max. 7t)	F7		•					
KL-0039-1914-1 - Pull spindle M14, hydraulic (max. 9t)	F8		•					
KL-0039-1916-1 - Pull spindle M16, hydraulic (max. 13t)	F9							
KL-0039-1920-1 - Pull spindle M20, hydraulic (max. 20t)	F10		•					
<b>Thrust spindle</b>								
KL-0039-1930 - Thrust spindle M20 x 350mm (max. 20t)	G1		•					
KL-0039-1931 - Thrust spindle M20 x 405mm (max. 20t)	G2		•					
<b>Press frame...</b>								
KL-0039-1140 - Press frame, light, short, 275mm (max. 12t)	J1	•						
KL-0039-1140 V - Press frame, reinforced, short, 275mm (max. 17t)	J2	•						
KL-0039-1153 - Pull rod M18, long, 375mm	J3	• 2x						

...Continued on the table on the following page!

Silent block/joint bearing tool sets						
KL-0039-1161 E	KL-0039-1190 EA	KL-0039-413 K	KL-0039-160 E	KL-0039-1601	KL-0039-170 E	KL-0039-1701

Pressure/supporting sleeves... (max. 17t)	Item	KL-0039-1161 E	KL-0039-1190 EA	KL-0039-413 K	KL-0039-160 E	KL-0039-1601	KL-0039-170 E	KL-0039-1701
KL-0039-1630 - Pressure/supporting sleeve 30/22mm dia., 45mm, short	H1			•	•	•		
KL-0039-1632 - Pressure/supporting sleeve 32/24mm dia., 45mm, short	H2				•	•		
KL-0039-1634 - Pressure/supporting sleeve 34/26mm dia., 45mm, short	H3				•	•		
KL-0039-1636 - Pressure/supporting sleeve 36/ 28mm dia., 45mm, short	H4				•	•		
KL-0039-1638 - Pressure/supporting sleeve 38/30mm dia., 45mm, short	H5				•	•		
KL-0039-1640 - Pressure/supporting sleeve 40/32mm dia., 45mm, short	H6			•	•	•		
KL-0039-1642 - Pressure/supporting sleeve 42/34mm dia., 45mm, short	H7				•	•		
KL-0039-1644 - Pressure/supporting sleeve 44/36mm dia., 45mm, short	H8				•	•		
KL-0039-1646 - Pressure/supporting sleeve 46/38mm dia., 45mm, short	H9			•	•	•		
KL-0039-1648 - Pressure/supporting sleeve 48/40mm dia., 45mm, short	H10				•	•		
KL-0039-1650 - Pressure/supporting sleeve 50/42mm dia., 45 mm, short	H11			•	•	•		
KL-0039-1652 - Pressure/supporting sleeve 52/44mm dia., 45mm, short	H12				•	•		
KL-0039-1654 - Pressure/supporting sleeve 54/46mm dia., 45mm, short	H13			•	•	•		
KL-0039-1656 - Pressure/supporting sleeve 56/48mm dia., 45mm, short	H14				•	•		
KL-0039-1658 - Pressure/supporting sleeve 58/50mm dia., 45mm, short	H15			•	•	•		
KL-0039-1660 - Pressure/supporting sleeve 60/52mm dia., 45mm, short	H16				•	•		
KL-0039-1662 - Pressure/supporting sleeve 62/54mm dia., 45mm, short	H17				•	•		
KL-0039-1664 - Pressure/supporting sleeve 64/56mm dia., 45mm, short	H18			•	•	•		
KL-0039-1666 - Pressure/supporting sleeve 66/58mm dia., 45mm, short	H19			•	•	•		
KL-0039-1668 - Pressure/supporting sleeve 68/60mm dia., 45mm, short	H20				•	•		
KL-0039-1670 - Pressure/supporting sleeve 70/62mm dia., 45mm, short	H21			•	•			
KL-0039-1672 - Pressure/supporting sleeve 72/64mm dia., 45mm, short	H22			•	•			
KL-0039-1674 - Pressure/supporting sleeve 74/66mm dia., 45mm, short	H23				•			
KL-0039-1676 - Pressure/supporting sleeve 76/68mm dia., 45mm, short	H24				•			
KL-0039-1678 - Pressure/supporting sleeve 78/70mm dia., 45mm, short	H25				•			
KL-0039-1680 - Pressure/supporting sleeve 80/72mm dia., 45 mm, short	H26				•			
KL-0039-1682 - Pressure/supporting sleeve 82/74mm dia., 45 mm, short	H27				•			
KL-0039-1684 - Pressure/supporting sleeve 84/76mm dia., 45 mm, short	H28				•			
KL-0039-1686 - Pressure/supporting sleeve 86/78mm dia., 45mm, short	H29				•			
KL-0039-1688 - Pressure/supporting sleeve 88/80mm dia., 45mm, short	H30				•			
KL-0039-1690 - Pressure/supporting sleeve 90/82mm dia., 45mm, short	H31				•			
KL-0039-1730 - Pressure/supporting sleeve 30/22mm dia., 115mm, long	H32						•	•
KL-0039-1732 - Pressure/supporting sleeve 32/24mm dia., 115mm, long	H33						•	•
KL-0039-1734 - Pressure/supporting sleeve 34/26mm dia., 115mm, long	H34						•	•
KL-0039-1736 - Pressure/supporting sleeve 36/28mm dia., 115mm, long	H35						•	•
KL-0039-1738 - Pressure/supporting sleeve 38/30mm dia., 115mm, long	H36						•	•
KL-0039-1740 - Pressure/supporting sleeve 40/32mm dia., 115mm, long	H37						•	•
KL-0039-1742 - Pressure/supporting sleeve 42/34mm dia., 115mm, long	H38						•	•
KL-0039-1744 - Pressure/supporting sleeve 44/36mm dia., 115mm, long	H39			•			•	•
KL-0039-1746 - Pressure/supporting sleeve 46/38mm dia., 115mm, long	H40						•	•
KL-0039-1748 - Pressure/supporting sleeve 48/40mm dia., 115mm, long	H41						•	•
KL-0039-1750 - Pressure/supporting sleeve 50/42mm dia., 115mm, long	H42			•			•	•
KL-0039-1752 - Pressure/supporting sleeve 52/44mm dia., 115mm, long	H43						•	•
KL-0039-1754 - Pressure/supporting sleeve 54/46mm dia., 115mm, long	H44						•	•
KL-0039-1756 - Pressure/supporting sleeve 56/48mm dia., 115mm, long	H45			•			•	•
KL-0039-1758 - Pressure/supporting sleeve 58/50mm dia., 115mm, long	H46						•	•
KL-0039-1760 - Pressure/supporting sleeve 60/52mm dia., 115mm, long	H47						•	•
KL-0039-1762 - Pressure/supporting sleeve 62/54mm dia., 115mm, long	H48			•			•	•
KL-0039-1764 - Pressure/supporting sleeve 64/56mm dia., 115mm, long	H49						•	•
KL-0039-1766 - Pressure/supporting sleeve 66/58mm dia., 115mm, long	H50			•			•	•
KL-0039-1768 - Pressure/supporting sleeve 68/60mm dia., 115mm, long	H51						•	•
KL-0039-1770 - Pressure/supporting sleeve 70/62mm dia., 115mm, long	H52			•			•	•
KL-0039-1772 - Pressure/supporting sleeve 72/64mm dia., 115mm, long	H53						•	•
KL-0039-1774 - Pressure/supporting sleeve 74/66mm dia., 115mm, long	H54			•			•	•
KL-0039-1776 - Pressure/supporting sleeve 76/68mm dia., 115mm, long	H55						•	•
KL-0039-1778 - Pressure/supporting sleeve 78/70mm dia., 115mm, long	H56			•			•	•
KL-0039-1780 - Pressure/supporting sleeve 80/72mm dia., 115mm, long	H57						•	•
KL-0039-1782 - Pressure/supporting sleeve 82/74mm dia., 115mm, long	H58			•			•	•
KL-0039-1784 - Pressure/supporting sleeve 84/76mm dia., 115mm, long	H59			•			•	•
KL-0039-1786 - Pressure/supporting sleeve 86/78mm dia., 115mm, long	H60						•	•
KL-0039-1788 - Pressure/supporting sleeve 88/80mm dia., 115mm, long	H61						•	•
KL-0039-1790 - Pressure/supporting sleeve 90/82mm dia., 115mm, long	H62						•	•

EN

**A = Hydraulic cylinder**



**B = Retaining adapter**

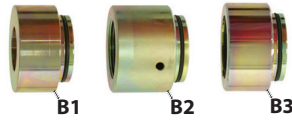

**D = Mechanical drive kit**



**C = Clamping nuts**



**E = Guide bolts**



**F = Pull spindles**

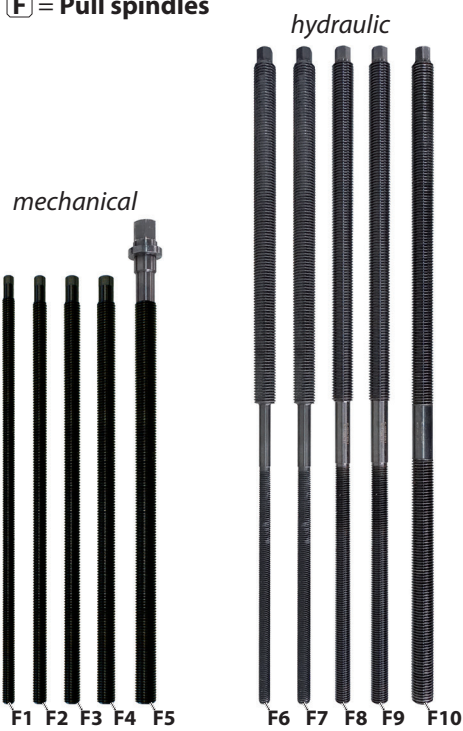

**G = Thrust spindles**



**H = Pressure/supporting sleeves**



**J = Press frames**

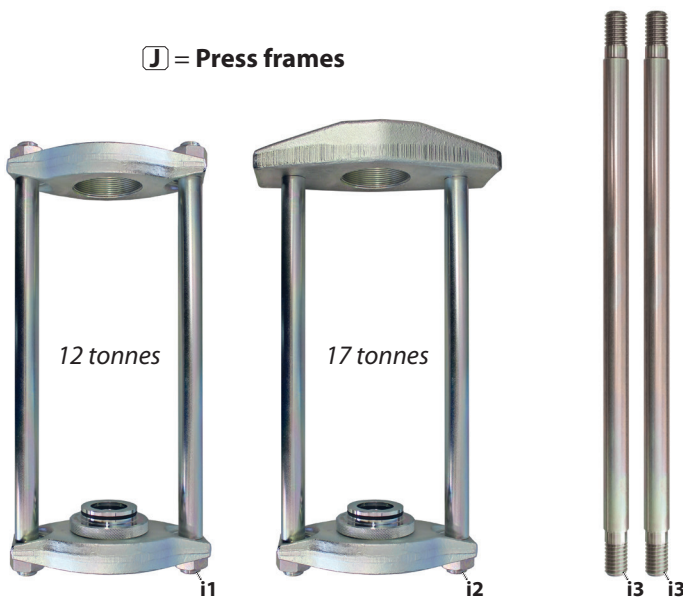

EN

### 3. PREPARATION

#### ⚠ WARNING

Misuse or **overloading** the silent block/joint bearing tool can cause it to slip, break and thus drop or be hurled about. This can cause **DEATH** or **SEVERE INJURIES!**

- ✔ **Prior to using** the silent block/joint bearing tool, read and understand **all** safety instructions and warnings listed in **Chapter 1** and **always observe** them **for safe use!**
- ✔ Use the silent block/joint bearing tool **as intended** and **always** carry out maintenance and repair work in compliance with the regulations on occupational safety and accident prevention as well as the vehicle manufacturer's instructions!
- ✔ **Before each use**, check the silent block/joint bearing tool **carefully** for damage, loose parts, or unauthorised modifications. **Never** use it if you notice any such deficiencies!
- ✔ **Always** wear your personal protective equipment (*such as safety goggles, protective gloves, safety shoes*) during work!

#### 3.1 Checking the scope of delivery

Prior to preparing the silent block/joint bearing tool, check that all parts of the scope of delivery are available (*see chapter 2.*), and follow the instructions below.

#### 3.2 Assembling drive parts

#### ⚠ WARNING

Using a machine-operated drive can cause the silent block/joint bearing tool to slip, break, and thus drop or fling around. This can cause **DEATH** or **SEVERE INJURIES!**

- ✔ **Never** use the silent block/joint bearing tool with a machine-operated drive. Drive it **exclusively** by hand with muscle power with a manual drive, or a manually driven GEDORE Automotive hydraulic cylinder/pump combination with pressure gauge for safe pressure control!
- ✔ **Never** use the silent block/joint bearing tool with an impulse or impact wrench!

1. Assemble the required drive parts for the silent block/joint bearing tool as shown in 1.

① *For other pressure plates see the GEDORE Automotive catalogue.*

1: Required drive parts

#### HYDRAULIC



#### (alternatively) MECHANICAL

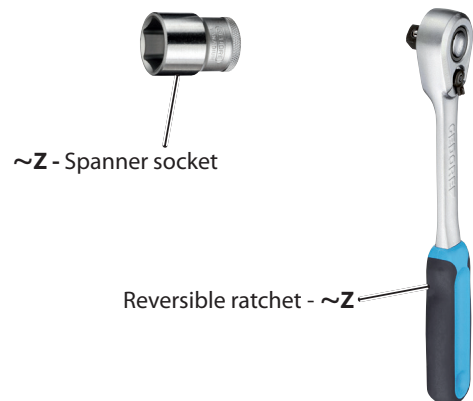

~To be used similarly like the hydraulic drive parts.

## 📷 2: Preparing the vehicle

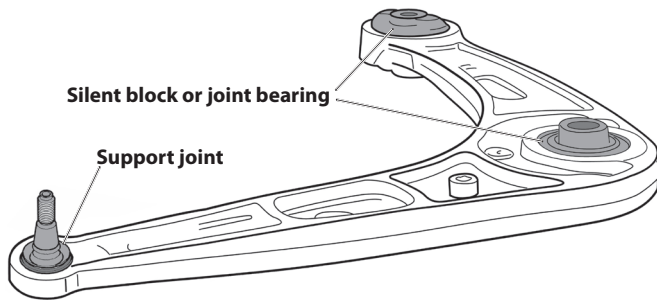

## 📷 3: Measure the outside diameter on the silent block or joint bearing.

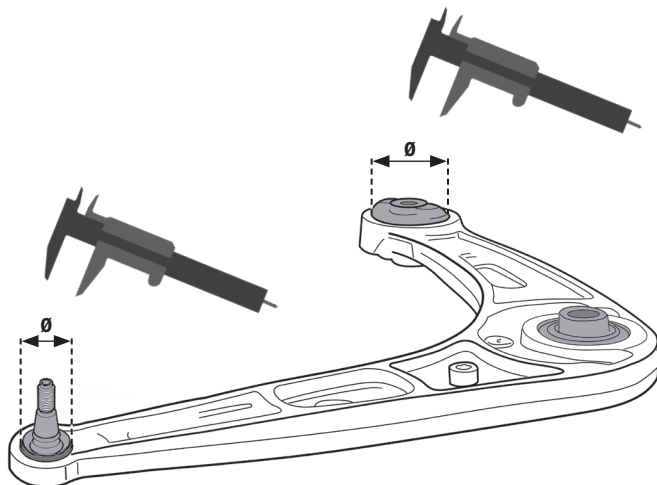

## 📷 4: Select the matching supporting sleeve.

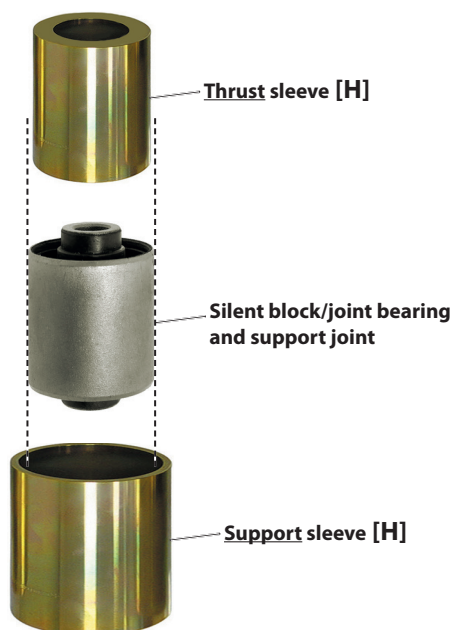

## 3.3 Preparing the vehicle

1. Safely lift the vehicle and prepare all necessary parts for the following work in accordance with the manufacturer's instructions.

## 3.4 Determining pressure sleeve and support sleeve

Depending on the type and diameter of the silent block/joint bearing or support joint, a suitable pressure and support sleeve must first be determined.

1. First measure the **outer** diameter of the silent block/joint bearing or support joint. 📷 3

### CAUTION

The thrust sleeve [H..] can be damaged when forcing out the silent block/joint bearing or support joint!

✔ The **outer** diameter of the pressure sleeve must not be **too large**, otherwise it can get stuck in the bearing hole when forcing out the silent block/joint bearing or support joint!

2. Based on the **outer** diameter of the silent / spherical bearing or suspension joint, select a suitable **thrust sleeve [H..]** with an **outer** diameter of **approx. 2 - 4mm smaller than** 📷 4.

### CAUTION

The supporting sleeve [H..] can be damaged when forcing out the silent block/joint bearing or support joint!

✔ The **inner** diameter of the pressure sleeve must not be **too small**; otherwise it can get stuck in the bearing hole when forcing out the silent block/joint bearing or support joint!

3. Based on the **outer** diameter of the silent block/joint bearing or suspension joint, select a suitable **supporting sleeve [H..]** with an **inner** diameter of **approx. 2 - 4mm larger than** 📷 4.

## 4. TYPICAL APPLICATIONS

These application examples describe the forcing out and forcing in of silent block/joint bearings and support joints in **three** different ways. This process follows the same principle, both mechanically and hydraulically.

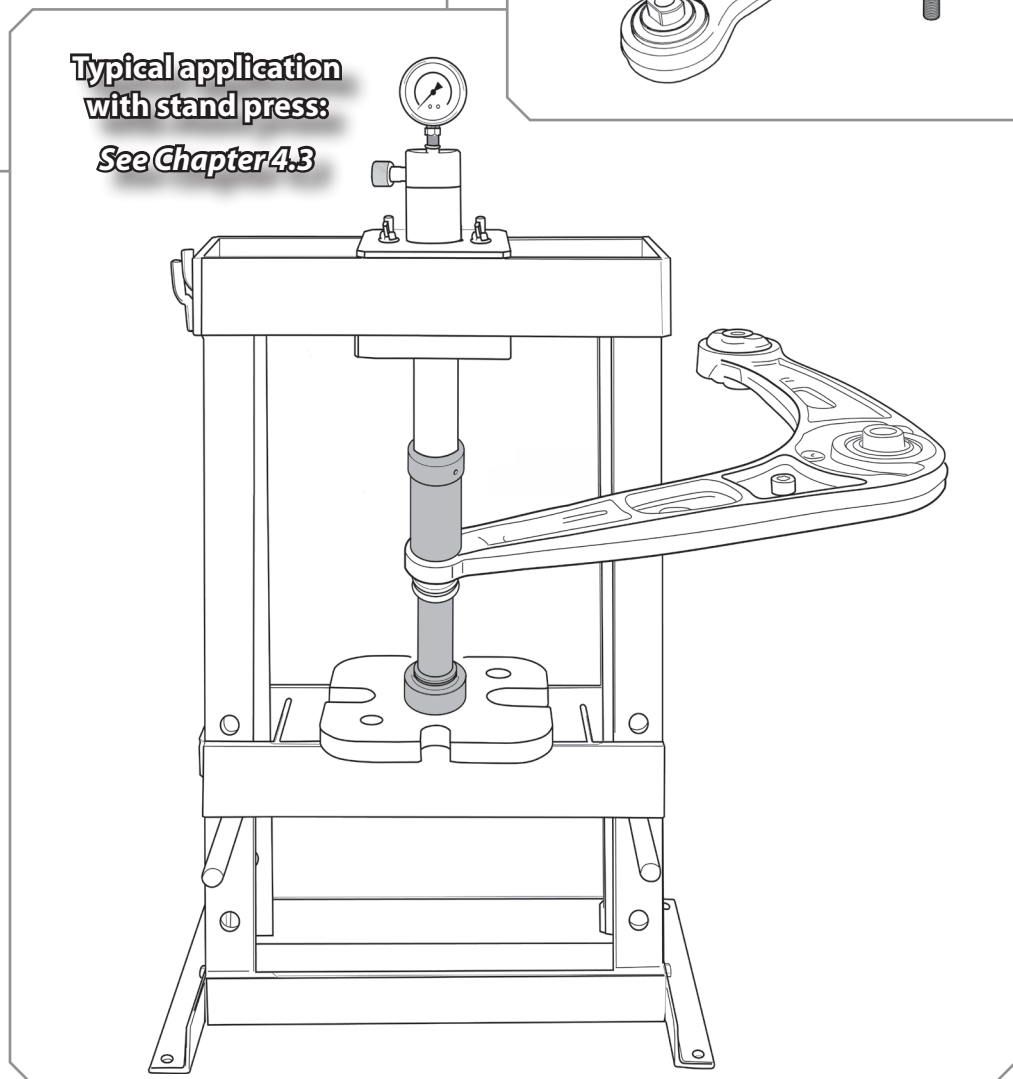
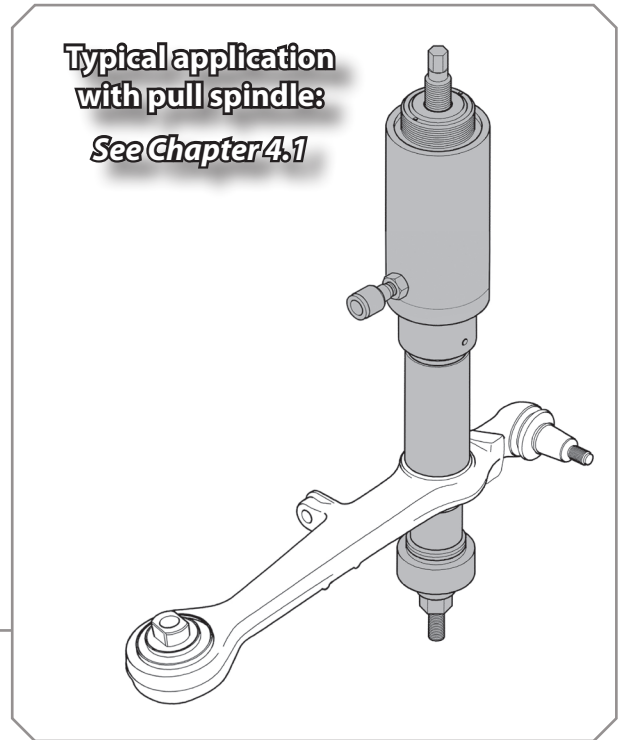
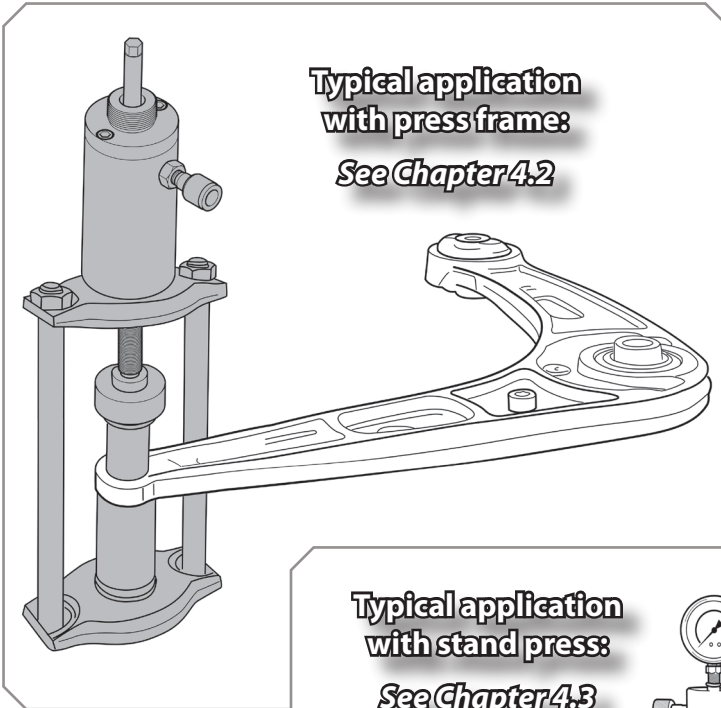

EN

**📷 5:** Assemble the silent block/joint bearing tool.

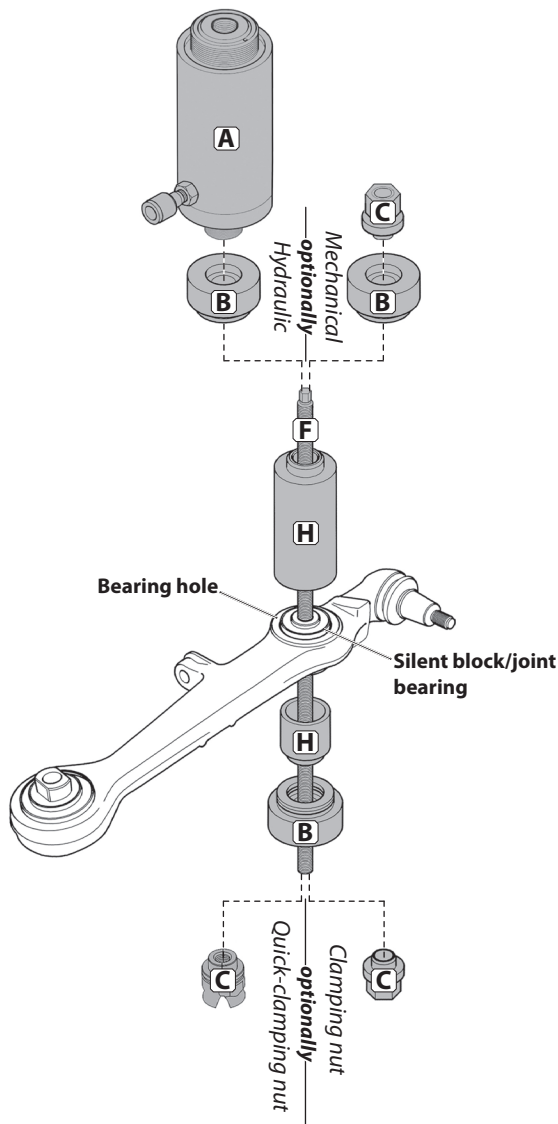

**📷 6:** Force out the silent block/joint bearing.



Observe the maximum load capacity!

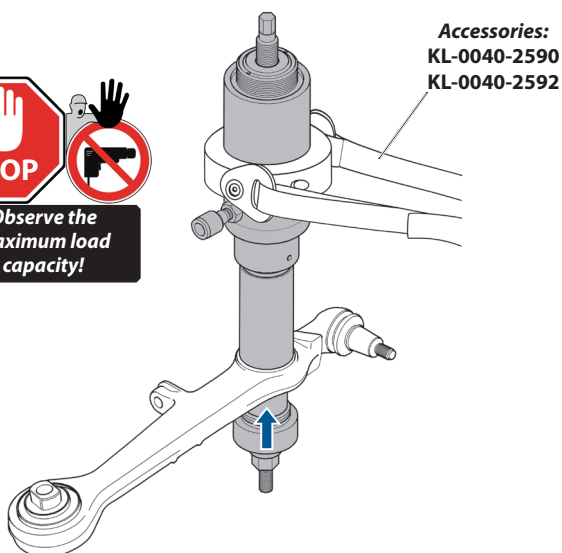

## 4.1 Forcing out and in by means of pull spindle

This typical application describes the hydraulic forcing out and forcing in of a silent block/joint using with a pull spindle. The process follows the same principle, both mechanically and hydraulically.

### Forcing out the silent block/joint bearing.

#### CAUTION

The press sleeve and the supporting sleeve [H..] can be damaged when forcing out the silent block/joint bearing!

- ▀ The press sleeve [H..] must rest with a right angle on at least two opposite surfaces on the silent block/joint bearing or support joint!
- ▀ The supporting sleeve [H..] must rest with a right angle on at least two opposite surfaces above the bearing hole!

1. Mount the silent block/joint bearing tool with all the required components as shown in **📷 5**.

#### ⚠ WARNING

There is the risk of the silent block/joint bearing tool breaking when a machine-operated drive is used. Parts flinging around can cause **DEATH** or **SEVERE INJURIES**.

- ▀ Use the silent block/joint bearing tool **exclusively** with a manual drive or a manually operated **GEDORE Automotive** hydraulic cylinder / pump combination with a pressure gauge for reliable pressure control!
2. Connect the hydraulic pump [Z] to the hydraulic cylinder [A].

#### ⚠ WARNING

The silent block/joint bearing tool can drop when being used! This can cause **SEVERE INJURIES** of the head or feet!

- ▀ Before use, **always** secure the silent block/joint bearing tool against falling off the vehicle or axle, e.g. using the safety retaining belt available as an accessory - **KL-0040-2590** or **KL-0040-2592**!

#### ⚠ WARNING

When forcing out the silent block/joint bearing, there is a risk of the pull spindle [F..] breaking and parts being hurled about. This can cause **DEATH** or **SEVERE INJURIES**.

- ▀ **Never** exceed the **max. load** of the pull spindle [F..] or the hydraulic cylinder [A..]!
  - ▀ **Constantly** watch the pressure on the pressure gauge at the hydraulic pump [Z] while forcing off.
  - ▀ While forcing out, **never** stand in the axial extension of the pull spindle [F..].
3. While operating the hydraulic pump [Z], watch the pressure on the pressure gauge, and force the silent block/joint bearing out. **📷 6**

① The maximum stroke of the hydraulic cylinder [A] is 50mm! As soon as this value is reached: Interrupt the forcing process, relieve the pressure at the hydraulic pump [Z], re-tighten the clamping nut [C..] until it is fully applied, and continue the forcing process.



**📷7:** Assemble the silent block/joint bearing tool.

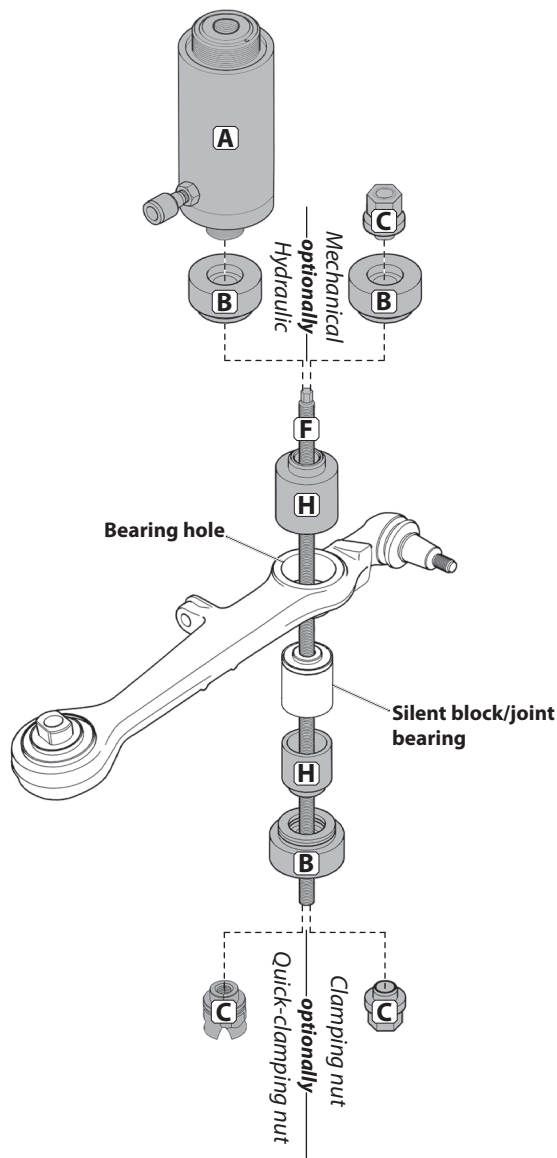

**📷8:** Force in the silent block/joint bearing.



**Observe the maximum load capacity!**

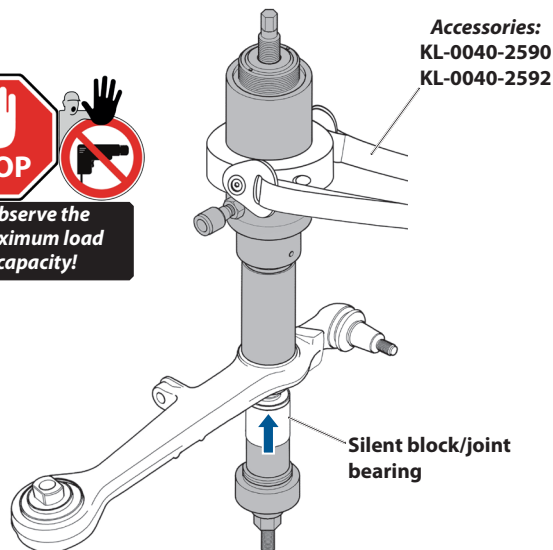

**Forcing in the silent block/joint bearing**

**CAUTION**

The press sleeve and the supporting sleeve [H..] can be damaged when forcing in the silent block/joint bearing!

- ▶ The press sleeve [H..] must rest with a right angle on at least two opposite surfaces on the silent block/joint bearing or support joint!
- ▶ The supporting sleeve [H..] must rest with a right angle on at least two opposite surfaces above the bearing hole!

1. Mount the silent block/joint bearing tool with all the required components and the new silent block/joint bearing as shown in **📷7**.

**CAUTION**

The silent block/joint bearing can be damaged during the press-in process!

- ▶ Observe the correct installation position of the silent block/joint bearing according to the manufacturer's instructions!
- ▶ Press in the silent block/joint bearing **always** with a right angle to the bearing hole!

**⚠WARNING**

The silent block/joint bearing tool can drop when being used! This can cause **SEVERE INJURIES** of the head or feet!

- ▶ Before use, **always** secure the silent block/joint bearing tool against falling off the vehicle or axle, e.g. using the safety retaining belt available as an accessory - **KL-0040-2590** or **KL-0040-2592!**

**⚠WARNING**

When forcing off the silent block/joint bearing, there is a risk of the pull spindle breaking and parts flinging around. This can cause **DEATH** or **SEVERE INJURIES**.

- ▶ **Never** exceed the **max. load** of the pull spindle [F..] or the hydraulic cylinder [A..]!
- ▶ **Constantly** watch the pressure on the pressure gauge at the hydraulic pump [Z] while forcing off.
- ▶ While forcing out, **never** stand in the axial extension of the pull spindle [F..].

2. While operating the hydraulic pump [Z], watch the pressure on the pressure gauge, and force the silent block/joint bearing out according to the manufacturer's instructions.

**📷8**

① The maximum stroke of the hydraulic cylinder [A] is 50mm! As soon as this value is reached: Interrupt the forcing process, relieve the pressure at the hydraulic pump [Z], re-tighten the clamping nut [C..] until it is fully applied, and continue the forcing process.

3. Relieve and disassemble the silent block/joint bearing tool, and carry out further work according to the manufacturer's instructions.

**📷9:** Assemble the silent block/joint bearing tool.

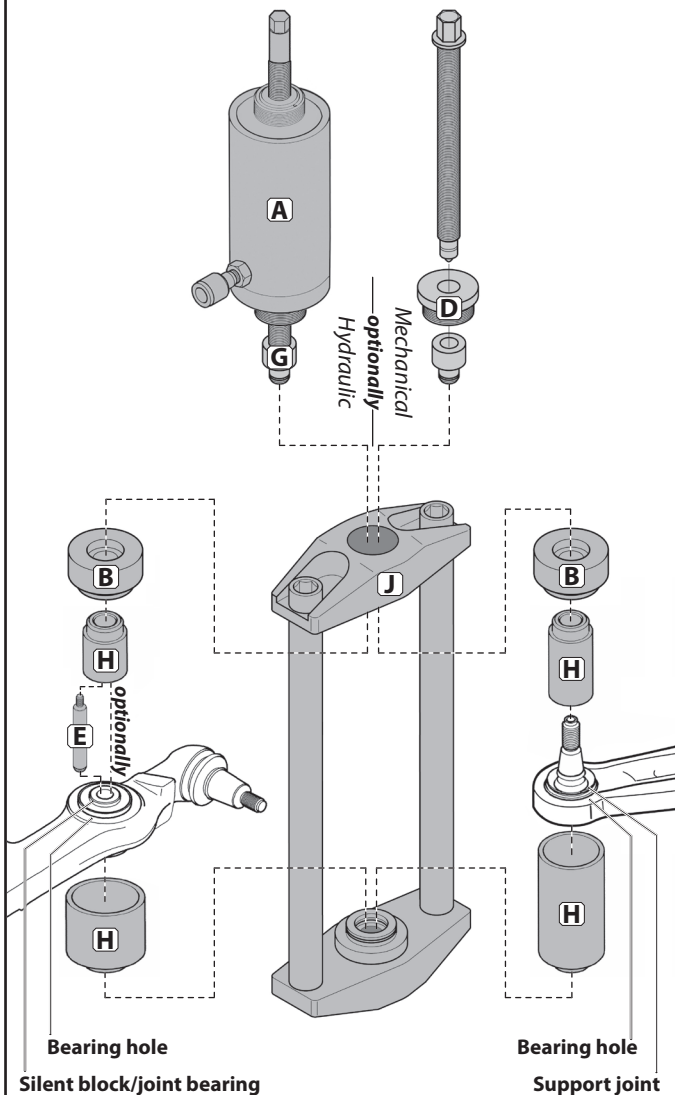

**📷10:** Press out the silent block/joint bearing and support joint.

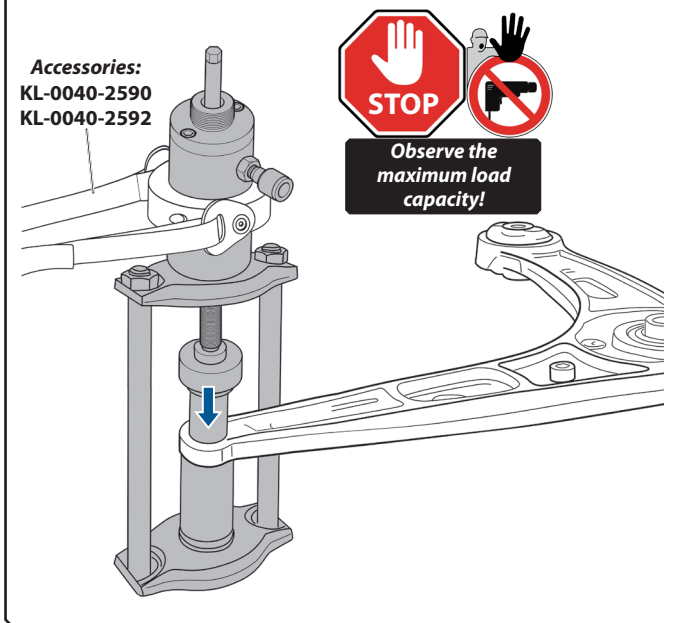

## 4.2 Forcing out and in by means of a press frame

This typical application describes the hydraulic forcing out and forcing in of a silent block/joint bearing and support joint using a press frame. The process follows the same principle, both mechanically and hydraulically.

### Forcing out the silent block/joint bearing and support joint.

#### CAUTION

The press sleeve and the supporting sleeve [H..] can be damaged when forcing out the silent block/joint bearing!

- ▶ The press sleeve [H..] must rest with a right angle on at least two opposite surfaces on the silent block/joint bearing or support joint!
- ▶ The supporting sleeve [H..] must rest with a right angle on at least two opposite surfaces above the bearing hole!

1. Mount the silent block/joint bearing tool with all the required components as shown in **📷9**.

#### ⚠WARNING

There is the risk of the silent block/joint bearing tool breaking when a machine-operated drive is used. Parts flinging around can cause **DEATH** or **SEVERE INJURIES**.

- ▶ Use the silent block/joint bearing tool **exclusively** with a manual drive or a manually operated **GEDORE Automotive** hydraulic cylinder / pump combination with a pressure gauge for reliable pressure control!
2. Connect the hydraulic pump [Z] to the hydraulic cylinder [A].

#### ⚠WARNING

The silent block/joint bearing tool can drop when being used! This can cause **SEVERE INJURIES** of the head or feet!

- ▶ Before use, **always** secure the silent block/joint bearing tool against falling off the vehicle or axle, e.g. using the safety retaining belt available as an accessory - **KL-0040-2590** or **KL-0040-2592**!

#### ⚠WARNING

When forcing out the silent block/joint bearing or support joint there is a risk of the pressure spindle [G..] breaking and parts being hurled about. This can cause **DEATH** or **SEVERE INJURIES**.

- ▶ **Never** exceed the **max. load** of the pressure spindle [G..], the hydraulic cylinder [A..], and the press frame [J..]!
  - ▶ **Constantly** watch the pressure on the pressure gauge at the hydraulic pump [Z] while forcing off.
  - ▶ While forcing out, **never** stand in the axial extension of the press frame [J..].
3. While operating the hydraulic pump [Z], watch the pressure on the pressure gauge, and force the silent block/joint bearing or support joint out. **📷10**

ⓘ The maximum stroke of the hydraulic cylinder [A] is 50mm! As soon as this value is reached: Interrupt the forcing process, relieve the pressure at the hydraulic pump [Z], retighten the pressure spindle [G..] until it is fully applied, and continue the forcing process.

**📷 11:** Assemble the silent block/joint bearing tool.

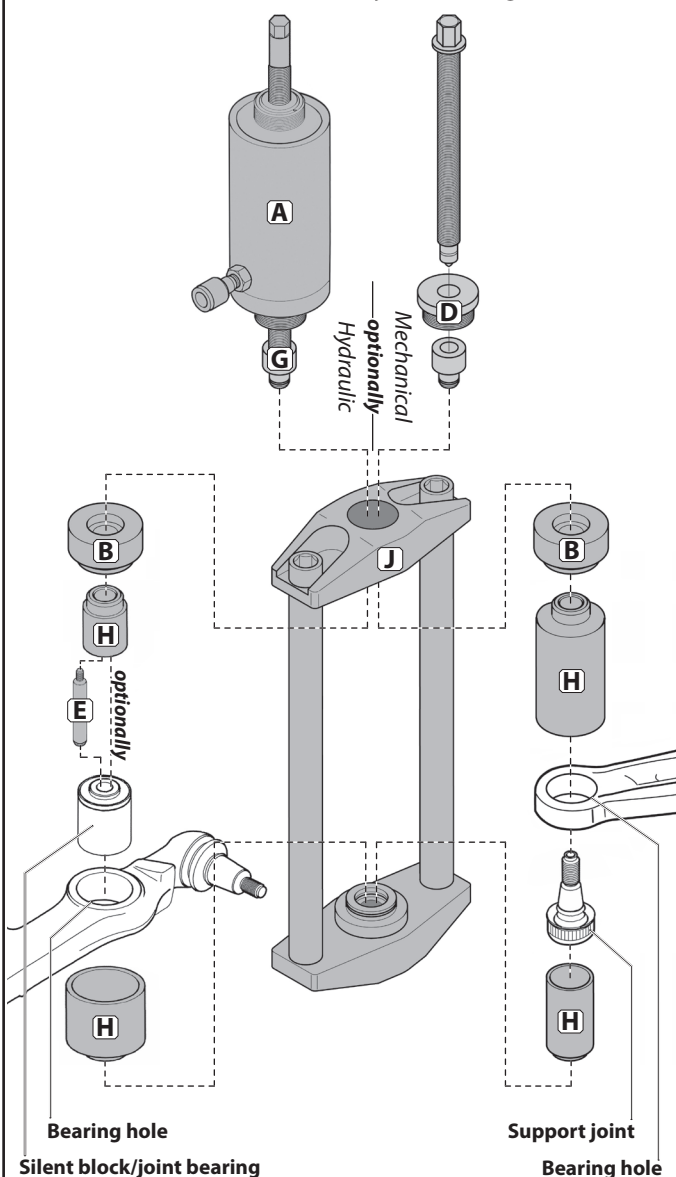

**📷 12:** Press in the silent block/joint bearing or support joint.

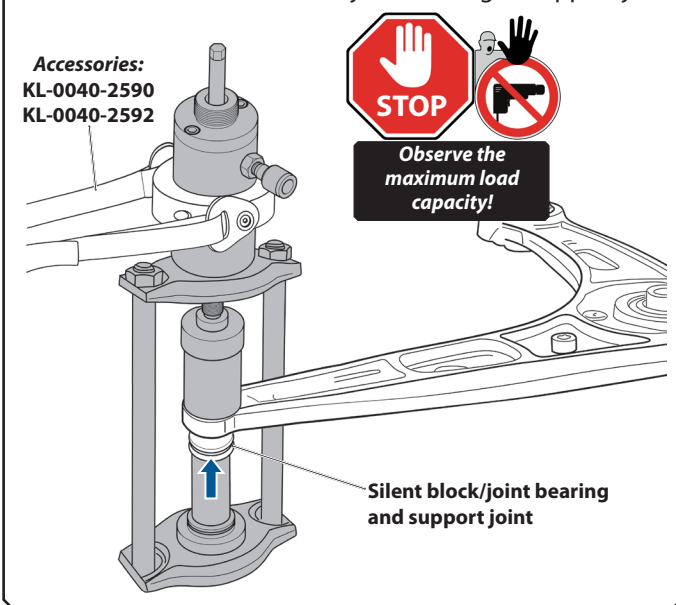

**Forcing in the silent block/joint bearing or support joint**

**CAUTION**

The press sleeve and the supporting sleeve [H..] can be damaged when forcing in the silent block/joint bearing or support joint!

- ▶ The press sleeve [H..] must rest with a right angle on at least two opposite surfaces on the silent block/joint bearing or support joint!
- ▶ The supporting sleeve [H..] must rest with a right angle on at least two opposite surfaces above the bearing hole!

1. Mount the silent block/joint bearing tool with all the required components and the new silent block/joint bearing or support joint as shown in **📷 11**.

**CAUTION**

The silent block/joint bearing or support joint can be damaged during the press-in process!

- ▶ Observe the correct installation position of the silent block/joint bearing or support joint according to the manufacturer's instructions!
- ▶ Press in the silent block/joint bearing or support joint **always** with a right angle to the bearing hole!

**⚠ WARNING**

The silent block/joint bearing tool can drop when being used! This can cause **SEVERE INJURIES** of the head or feet!

- ▶ Before use, **always** secure the silent block/joint bearing tool against falling off the vehicle or axle, e.g. using the safety retaining belt available as an accessory - **KL-0040-2590** or **KL-0040-2592!**

**⚠ WARNING**

When forcing in the silent block/joint bearing or support joint, there is a risk of the pressure spindle [G..] breaking and parts being hurled about. This can cause **DEATH** or **SEVERE INJURIES**.

- ▶ **Never** exceed the **max. load** of the pressure spindle [G..], the hydraulic cylinder [A..], and the press frame [J..]!

- ▶ **Constantly** watch the pressure on the pressure gauge at the hydraulic pump [Z] while forcing off.

- ▶ While forcing out, **never** stand in the axial extension of the press frame [J..].

2. While operating the hydraulic pump [Z], watch the pressure on the pressure gauge, and force the silent block/joint bearing in according to the manufacturer's instructions. **📷 12**

**ⓘ** The maximum stroke of the hydraulic cylinder [A] is 50mm! As soon as this value is reached: Interrupt the forcing process, relieve the pressure at the hydraulic pump [Z], re-tighten the pressure spindle [G..] until it is fully applied, and continue the forcing process.

3. Relieve and disassemble the silent block/joint bearing tool, and carry out further work according to the manufacturer's instructions.

📷 13: Assemble the silent block/joint bearing tool.

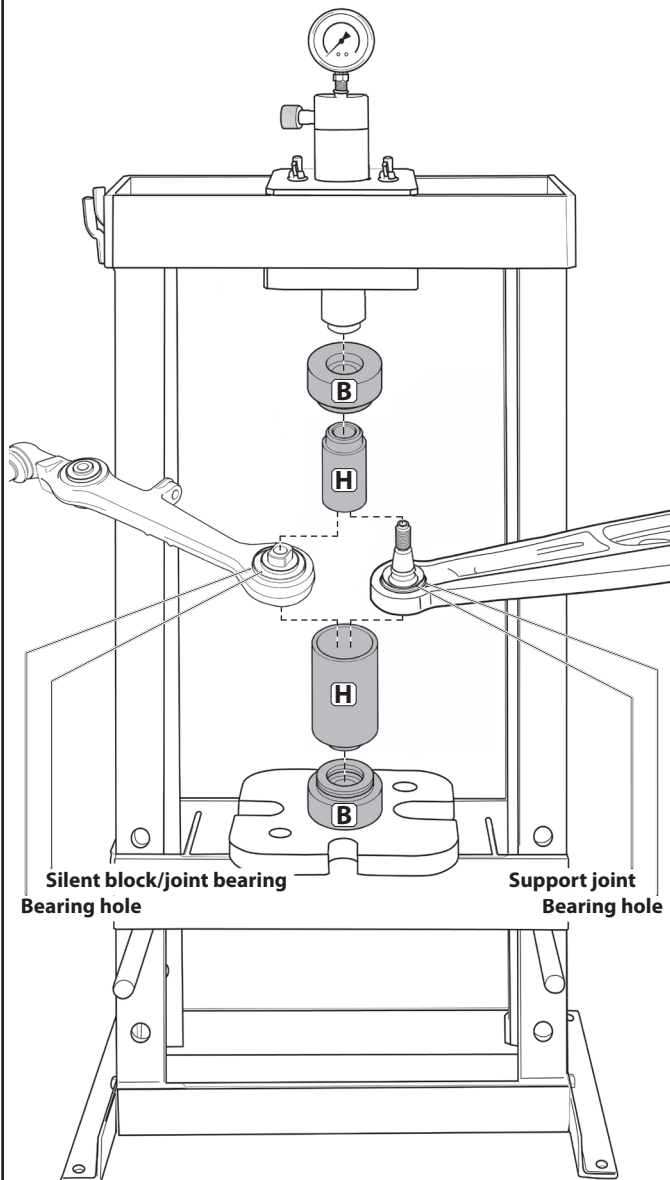

## 4.3 Forcing out and in by means of a stand press

This typical application describes the hydraulic forcing out and forcing in of a silent block/joint bearing or support joint using a stand press.

### Forcing out the silent block/joint bearing and support joint

#### CAUTION

The press sleeve and the supporting sleeve [H..] can be damaged when forcing out the silent block/joint bearing!

✔ The press sleeve [H..] must rest with a right angle on at least two opposite surfaces on the silent block/joint bearing or support joint!

✔ The supporting sleeve [H..] must rest with a right angle on at least two opposite surfaces above the bearing hole!

1. Insert all the required components of the silent block/joint bearing tool into a stand press as shown in 📷 13.

#### ⚠ WARNING

There is the risk of the silent block/joint bearing tool breaking when a machine-operated drive is used. Parts flinging around can cause **DEATH** or **SEVERE INJURIES**.

✔ **Only** use the silent block/articulated bearing tool via a manually operated stand press, with pressure gauge for safe pressure control!

#### ⚠ WARNING

When forcing out the silent block/joint bearing or support joint there is a risk of breaking and parts being hurled about. This can cause **DEATH** or **SEVERE INJURIES**.

✔ **Never** exceed the **max. load** of the pressure/supporting sleeves [H..] and the stand press!

✔ **Always** read, understand, and observe **also** the manufacturer-specific safety instructions and instructions for the stand press!

✔ **Constantly** watch the pressure on the pressure gauge at the stand press while forcing off.

2. While operating the stand press, watch the pressure on the pressure gauge and force the silent block/joint bearing or support joint out. 📷 14

📷 14: Press out the silent block/joint bearing and support joint.

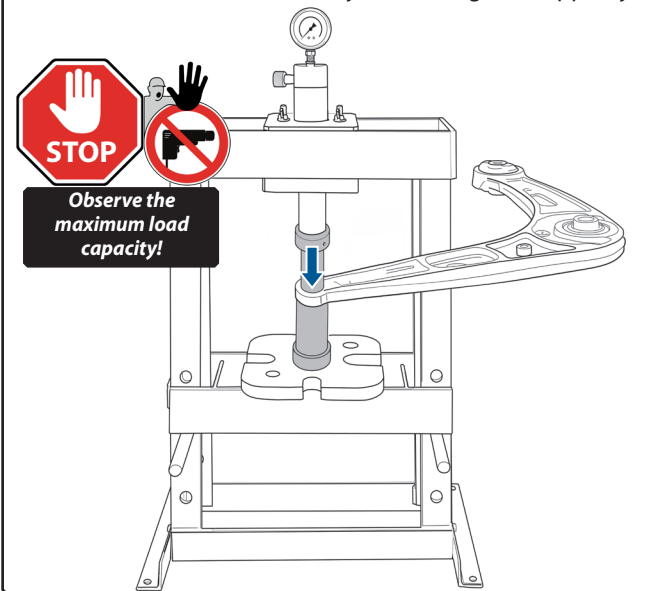

**15:** Assemble the silent block/joint bearing tool.

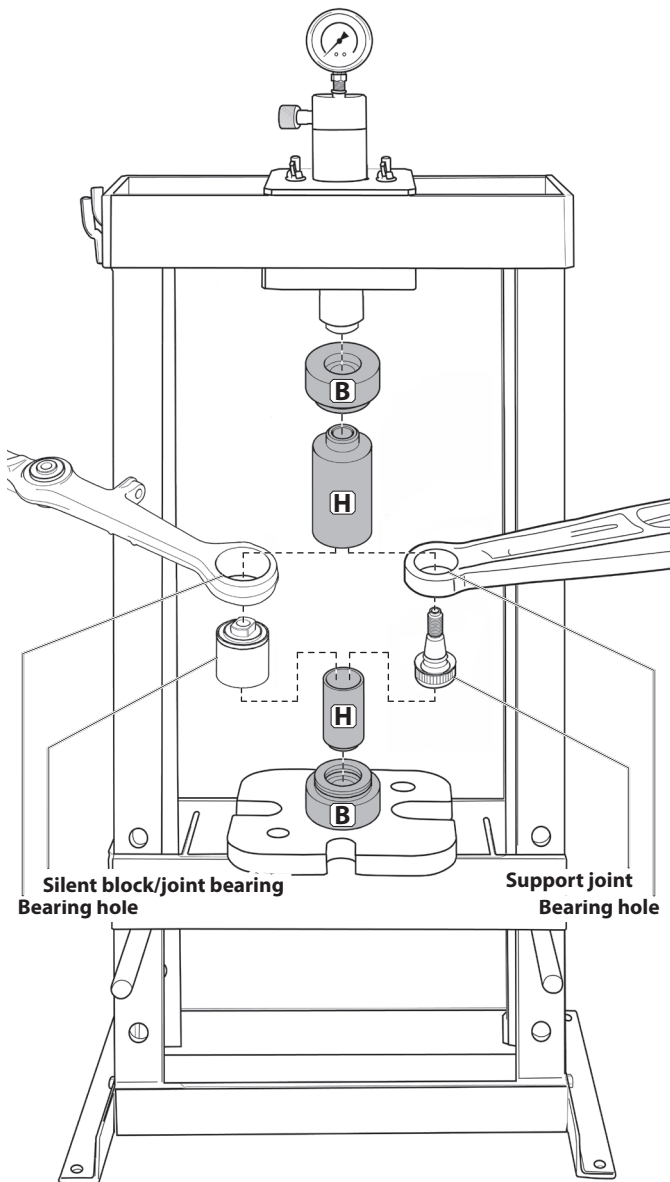

**Forcing in the silent block/joint bearing or support joint**

**CAUTION**

The press sleeve and the supporting sleeve [H..] can be damaged when forcing in the silent block/joint bearing!

- ▣ The press sleeve [H..] must rest with a right angle on at least two opposite surfaces on the silent block/joint bearing or support joint!
- ▣ The supporting sleeve [H..] must rest with a right angle on at least two opposite surfaces above the bearing hole!

1. Insert all the required components of the silent block/joint bearing or support joint into a stand press as shown in **15**.

**CAUTION**

The silent block/joint bearing or support joint can be damaged during the press-in process!

- ▣ Observe the correct installation position of the silent block/joint bearing or support joint according to the manufacturer's instructions!
- ▣ Press in the silent block/joint bearing or support joint **always** with a right angle to the bearing hole!

**!WARNING**

When forcing in the silent block/joint bearing or support joint, there is a risk of breaking and parts being hurled about. This can cause **DEATH** or **SEVERE INJURIES**.

- ▣ **Never** exceed the **max. load** of the pressure/supporting sleeves [H..] and the stand press!
- ▣ **Always** read, understand, and observe **also** the manufacturer-specific safety instructions and instructions for the stand press!

▣ **Constantly** watch the pressure on the pressure gauge at the stand press while forcing off.

2. Operate the stand press, watch the pressure on the pressure gauge, and force the silent block/joint bearing or support joint in according to the manufacturer's instructions. **16**

**16:** Press in the silent block/joint bearing or support joint.

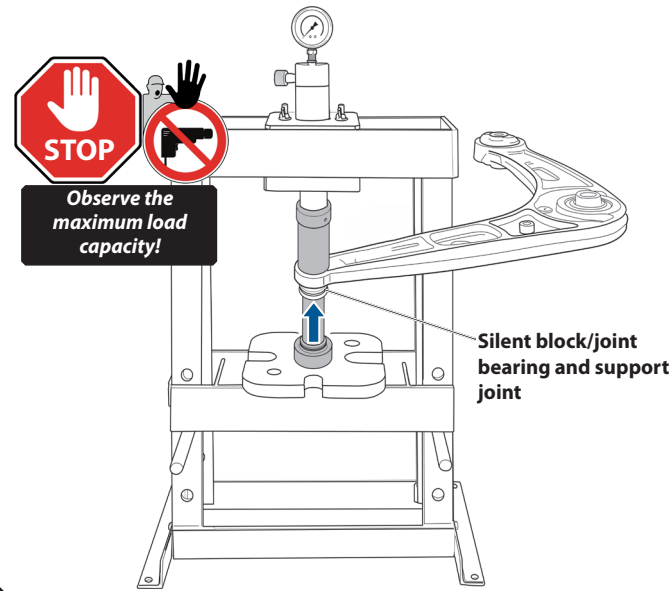

3. Relieve and disassemble the components of the silent block/joint bearing tool, and carry out further work according to the manufacturer's instructions.

EN

**📷 17: Press frame set - KL-0039-1161 E**

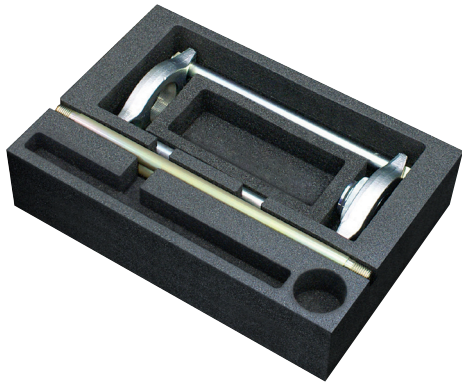

**📷 18: Spindle/drive set - KL-0039-190 EA**



**📷 19: Pull devices for silent blocks - KL-0039-413 K**



## 5. CARE AND STORAGE

### ATTENTION

Improper care and storage can damage the silent block/joint bearing tool. **Never** immerse the silent block/joint bearing tool in water, solvents, or other cleaning liquids. After use, clean all parts **only** with a dry and clean cleaning cloth. To protect against corrosion, rub all metal parts with a tool care oil or wax. Store the silent block/joint bearing tool and the operating instructions at a dry and clean place.

## 6. REPAIR

### ⚠️ WARNING

For safety reasons, ensure that a damaged silent block/joint bearing tool is no longer used! Professional inspection and repair may only be carried out by specially trained personnel from **GEDORE Automotive GmbH**. Improper repair can result in **DEATH** or **SEVERE INJURIES**.

## 7. SILENT BLOCK/JOINT BEARING TOOLS

### KL-0039-1161 E - Press frame set in foam insert (📷 17)

For mechanical or hydraulic forcing out and forcing in of bearings, bushings, and joints in connection with the tools of the **KL-0039-.. series**.

📄 Scope of supply/single part overview see **chapter 2.2**

### KL-0039-190 EA - Spindle set/drive set in foam insert (📷 18)

The spindle/drive set ensures organised and well-structured working with the **KL-0039-..** wheel bearing and silent block tool series. The drive parts included in the set are required for working with the **KL-0039-..series** for removing and installing bearings, bushings, and joints.

📄 Scope of supply/single part overview see **chapter 2.2**

### KL-0039-413 K - Pulling device for silent blocks, mechanical, in plastic case (📷 19)

Universal fit for silent blocks or joint bearings of 30 to 73mm dia. The pulling device enables quick and professional removal and installation of silent blocks or joint bearings. The mechanical drive included in the set ensures the extraction of silent or spherical bearings from an inner bore diameter of 10mm.

For very tight or corroded silent blocks, a hydraulic drive from GEDORE Automotive can also be used as an option. The additional use of a press frame also enables the removal and installation of support joints, for example, and others.

📄 Scope of supply/single part overview see **chapter 2.2**

**📷 20:** Pressure/supporting sleeve set, short - **KL-0039-160 E**

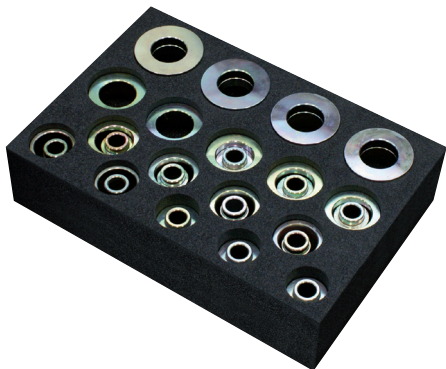

**KL-0039-160 E - Pressure/supporting sleeve set  
30 - 90mm dia., short, 45mm, in  
foam insert (📷20)**

For forcing out and forcing in of silent blocks, shafts, bushings in connection with the tools of the **KL-0039-.. series**.

📷 Scope of supply/single part overview see **chapter 2.2**

**📷 21:** Pressure/supporting sleeve set, short + Pin - **KL-0039-1601**



**KL-0039-1601 - Pressure/supporting sleeve set  
30 - 68mm dia., with guide bolts  
(📷21)**

For forcing out and forcing in of silent blocks, shafts, bushings in connection with the tools of the **KL-0039-.. series**.

Includes guide bolts for proper fitting of silent blocks.

📷 Scope of supply/single part overview see **chapter 2.2**

**📷 22:** Pressure/supporting sleeve set, long - **KL-0039-170 E**

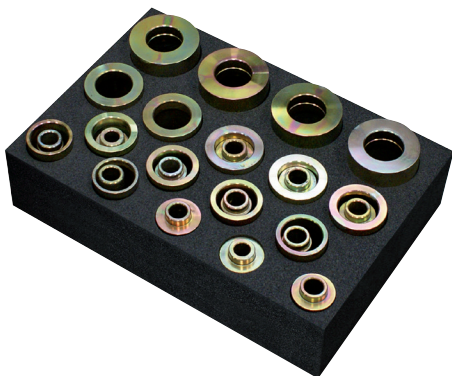

**KL-0039-170 E - Pressure/supporting sleeve set  
30 - 90mm dia., long, 45mm, in  
foam insert (📷22)**

For forcing out and forcing in of silent blocks, shafts, bushings in connection with the tools of the **KL-0039-.. series**.

📷 Scope of supply/single part overview see **chapter 2.2**

**📷 23:** Pressure/supporting sleeve set, long + Pin - **KL-0039-1701**



**KL-0039-1701 - Pressure/supporting sleeve set  
30 - 68mm dia., long, with guide  
bolts (📷23)**

For forcing out and forcing in of silent blocks, shafts, bushings in connection with the tools of the **KL-0039-.. series**.

Includes guide bolts for proper fitting of silent blocks.

📷 Scope of supply/single part overview see **chapter 2.2**

📷 **Further accessories and drive parts can also be found in the GEDORE Automotive catalogue!**

**8. ENVIRONMENTALLY COMPLIANT  
DISPOSAL**

Dispose of the silent block/joint bearing tool and its packaging material in an environmentally acceptable manner in accordance with the legal requirements. If necessary, ask your local authorities about environmentally friendly disposal options.

EN

## GEDORE-Werkzeugfabrik GmbH & Co. KG

Remscheider Straße 149  
42899 - Remscheid  
Postfach 120361  
47873 Remscheid  
GERMANY

### Vertrieb DEUTSCHLAND

☎ +49 (0) 2191 / 596-0  
☎ +49 (0) 2191 / 596-230  
✉ info@gedore.com  
🌐 www.gedore.com

### Sales INTERNATIONAL

☎ +49 (0) 2191 / 596-910  
☎ +49 (0) 2191 / 596-911  
✉ info@gedore.com  
🌐 www.gedore.com

## GEDORE TOOLS, INC.

Only for USA, Canada & Mexico  
Sólo para EE.UU., Canadá y México  
Seulement pour les USA, le Canada et le Mexique  
7187 Bryhawke Circle, Suite 700, North Charleston, SC 29418, USA

☎ +1-843 / 225 50 15  
☎ +1-843 / 225 50 20  
✉ info@gedoretools.com  
🌐 www.gedoretools.com

Worldwide GEDORE service centers and offices are listed on the Internet at: [www.gedore.com](http://www.gedore.com)

## GEDORE Automotive GmbH

Breslauer Straße 41  
78166 - Donaueschingen  
Postfach 1329  
78154 Donaueschingen  
GERMANY

### Vertrieb DEUTSCHLAND

☎ +49 (0) 771 / 8 32 23-0  
☎ +49 (0) 771 / 8 32 23-90  
✉ info.gam@gedore.com  
🌐 gedore-automotive.com



[www.gedore-automotive.com](http://www.gedore-automotive.com)