

S90SN-R

SCHEIBENFRÄSER DISC MILLING CUTTERS

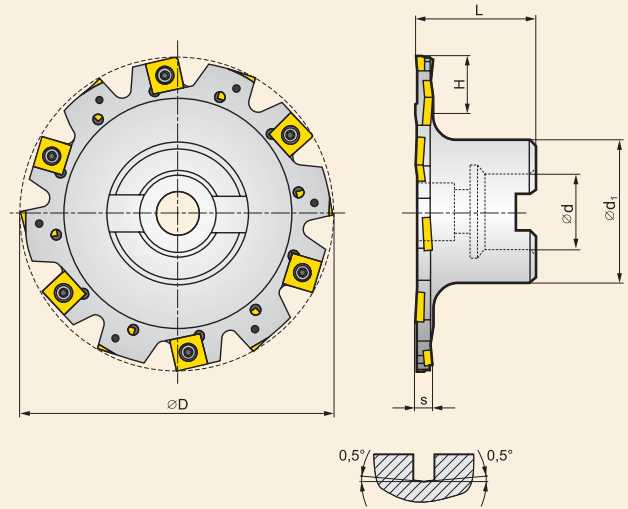

Z* - Anzahl Zähne / Number of teeth
K* - Effektive Zähnezahl / Effective number of teeth

| | | | |
|------------|--------|--------------|-----|
| γ_p | -0°30' | κ_r | 90° |
| γ_f | +2°30' | $a_{e\ max}$ | H |

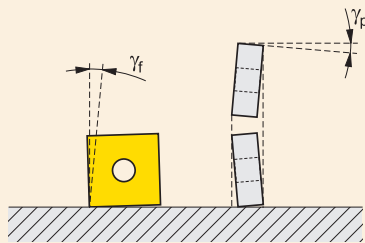

Abmessungen [mm]. / Dimensions [mm].

| ISO | Sortiment / Assortment | Abmessungen / Dimensions | | | | | | | | | Kühlung Cooling | [kg] |
|--------------------|------------------------|--------------------------|----|------|----|-------|----|----|----|--|--------------------|------|
| | | D | d | H | s | d_1 | Z* | K* | L | | | |
| 63A03R-S90SN11N4 | ● | 63 | 16 | 10,5 | 4 | 34 | 6 | 3 | 40 | | | 0,5 |
| 63A03R-S90SN11N5 | ○ | 63 | 16 | 10,5 | 5 | 34 | 6 | 3 | 40 | | | 0,5 |
| 63A03R-S90SN12N6 | ○ | 63 | 16 | 10,5 | 6 | 34 | 6 | 3 | 40 | | | 0,5 |
| 80A04R-S90SN11N5 | ● | 80 | 22 | 17,5 | 5 | 40 | 8 | 4 | 40 | | | 0,6 |
| 80A04R-S90SN12N6 | ● | 80 | 22 | 17,5 | 6 | 40 | 8 | 4 | 40 | | | 0,6 |
| 100A05R-S90SN12N6 | ● | 100 | 27 | 23,5 | 6 | 48 | 10 | 5 | 50 | | | 0,7 |
| 125B06R-S90SN12N6 | ○ | 125 | 40 | 24,0 | 6 | 70 | 12 | 6 | 50 | | | 1,5 |
| 160B08R-S90SN12N10 | ○ | 160 | 40 | 41,0 | 10 | 70 | 16 | 8 | 50 | | | 2,1 |

ERSATZTEILE / SPARE PARTS

*) Empfohlene Torxschraube – siehe Seite / For screw torques see pages: 394 – 397.

| Fräser Marking of cutter | Spannschraube* Clamping screw* | Schraubendreher Screwdriver | Schraube für Messerkopf Screw for taper clamping |
|-----------------------------|-----------------------------------|--------------------------------|---|
| 63A03R-S90SN11N4 | US 3504-T09P | SDR T09P | HS 0830 |
| 63A03R-S90SN11N5 | US 3505-T09P | SDR T09P | HS 0830 |
| 63A03R-S90SN12N6 | US 70 | SDR T15 | HS 0830 |
| 80A04R-S90SN11N5 | US 3505-T09P | SDR T09P | HS 1030 |
| 80A04R-S90SN12N6 | US 70 | SDR T15 | HS 1030 |
| 100A05R-S90SN12N6 | US 70 | SDR T15 | HS 1230 |
| 125B06R-S90SN12N6 | US 70 | SDR T15 | - |
| 160B08R-S90SN12N10 | US 72 | SDR T15 | - |

