

S45OD05D

PLANFRÄSER
POSITIVE FACE MILLING CUTTERS

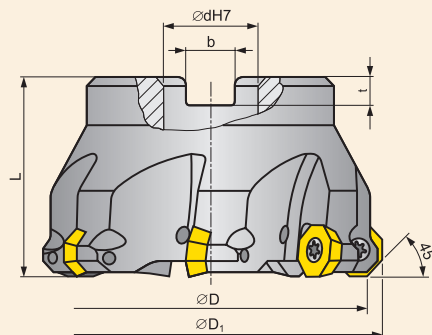

γ_p	+7°	κ_r	45°
γ_f	0°	$a_{p\ max}$	7,3 mm

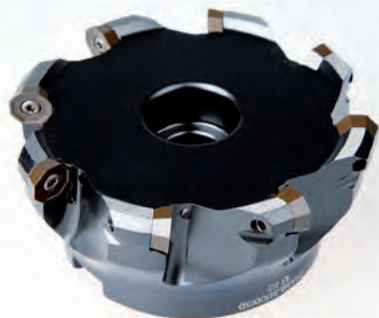
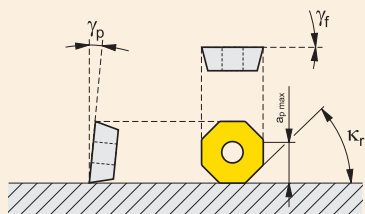

Z* - Anzahl Zähne / Number of teeth

Abmessungen [mm]. / Dimensions [mm].

ISO	Sortiment / Assortment	Abmessungen / Dimensions								Kühlung / Cooling	[kg]
		D ₁	D	d	L	b	t	Z*			
40A04R-S45OD05D	○	48	40	16	40	8,4	5,6	4		+	1,10
50A05R-S45OD05D	○	58	50	22	40	10,4	6,3	5		+	1,30
63A06R-S45OD05D	○	71	63	22	40	10,4	6,3	6		+	2,00
80A07R-S45OD05D	○	88	80	27	50	12,4	7,0	7		+	2,70
100A08R-S45OD05D	○	108	100	32	50	14,4	8,0	8		+	6,00
125A10R-S45OD05D	○	133	125	40	63	16,4	9,0	10		+	10,00

PLANFRÄSER
FACE MILLING CUTTERS

ECKFRÄSER
SHOULDER END MILLING CUTTERS

WALZENSTIRNFRÄSER/SCHLEIFENFRÄSER
SQUARE SHOULDER/SLOT MILLING CUTTERS

KOPIERFRÄSER
COPY MILLING CUTTERS

FRÄSER FÜR SPEZ. ANWENDUNGEN
CUTTERS FOR SPECIAL APPLICATION

WENDESCHNEIDPLATTEN
INDEXABLE INSERTS

S450D05D

PLANFRÄSER
INSERTS FOR POSITIVE FACE MILLS

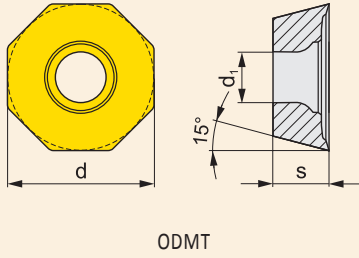

ODMT

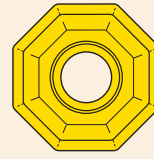

ODMT ZZN

WENDESCHNEIDPLATTEN (WSP) / INDEXABLE CUTTING INSERTS

ISO	Materialien / Grades						Abmessungen / Dimensions						
	M5315	M9315	M9325	M8340	8230	8240	d	s	d ₁				
ODMT 0504ZZN	●	●	●	●	●	●	12,700	4,760	4,40				

ERSATZTEILE / SPARE PARTS

*) Empfohlene Torxschraube – siehe Seite / For screw torques see pages: 394 – 397.

∅ Fräser
∅ Cutter

Spannschraube*
Clamping screw*



Schraubendreher
Screwdriver

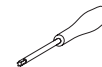

40 – 125

US 3509-T15

SDR T15