

# ATA SDM37/30/26 LR-125 EXTENDED SERIES TOOLS PARTS LIST

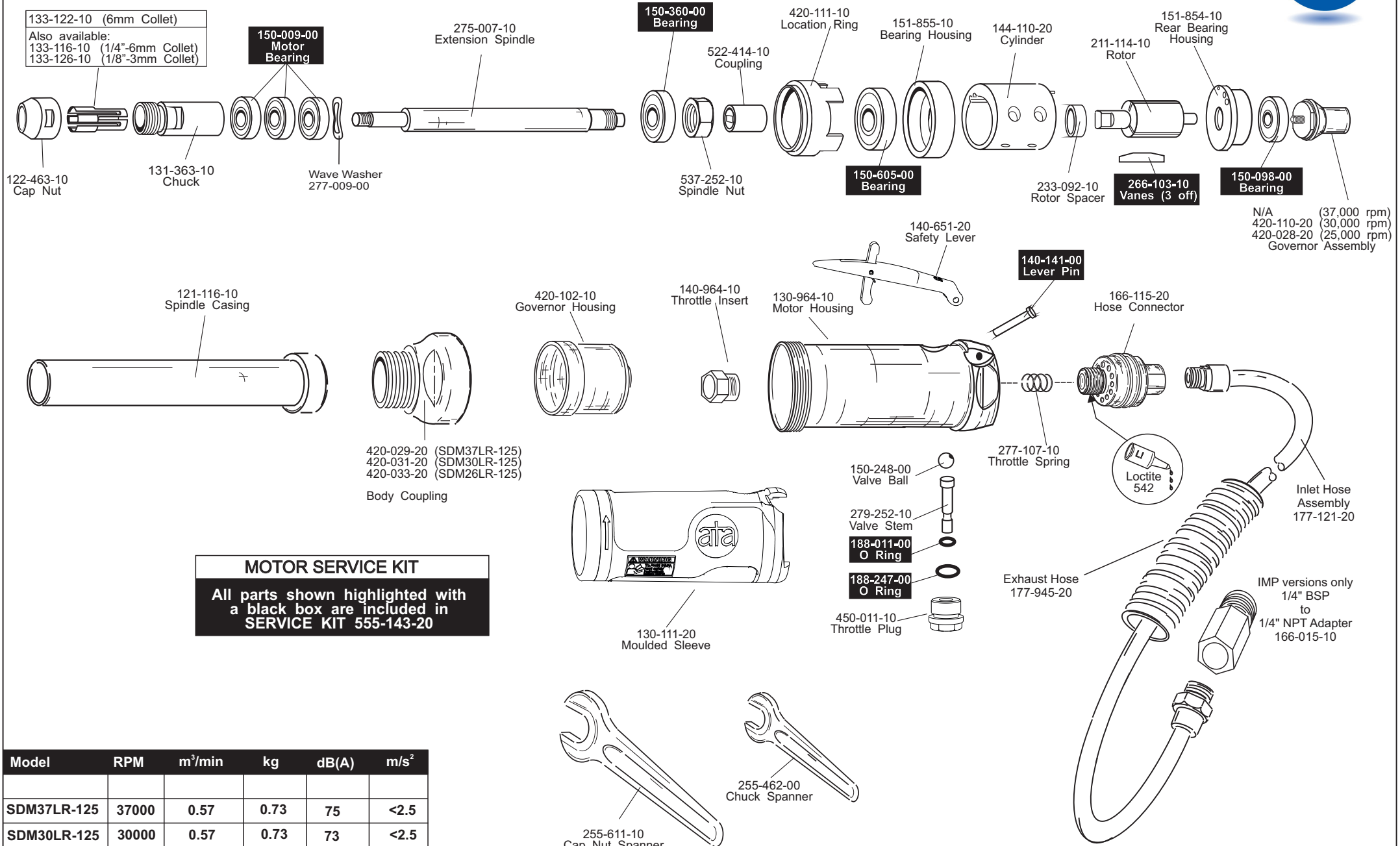

990-508-10 120918



**MOTOR SERVICE KIT**  
All parts shown highlighted with a black box are included in SERVICE KIT 555-143-20

Model	RPM	m <sup>3</sup> /min	kg	dB(A)	m/s <sup>2</sup>
SDM37LR-125	37000	0.57	0.73	75	<2.5
SDM30LR-125	30000	0.57	0.73	73	<2.5
SDM26LR-125	25000	0.57	0.73	72	<2.5

STRIPPING TOOL SET PART NUMBER 900-117-20