

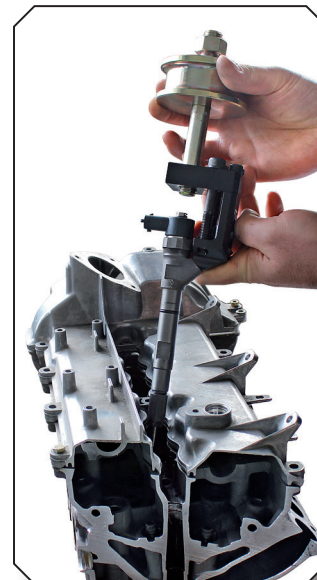

KL-0186-9..A Series Injector Puller Kits



Operating instructions EN
 ⚠ Read and understand before use!



www.gedore-automotive.com

GEDORE Automotive GmbH

Breslauer Straße 41
 78166 - Donaueschingen
 Postfach 1329
 78154 Donaueschingen - GERMANY

☎ +49 (0) 771 / 8 32 23-0
 ☎ +49 (0) 771 / 8 32 23-90
 ✉ info.gam@gedore.com
 🌐 gedore-automotive.com

GEDORE TOOLS, INC.

Only for USA, Canada & Mexico / Sólo para EE.UU., Canadá y México
 Seulement pour les USA, le Canada et le Mexique
 7187 Bryhawke Circle, Suite 700
 North Charleston, SC 29418, USA

☎ +1-843 / 225 50 15
 ☎ +1-843 / 225 50 20
 ✉ info@gedoretools.com
 🌐 gedore.com

Version 08/2022

0186-9..ASerie_EN220808.indd



ENGLISH

EN

Manufacturer's address

GEDORE Automotive GmbH

Breslauer Straße 41 // 78166 Donaueschingen - GERMANY

☎ +49 (0)771/83223-71 // ✉ info.gam@gedore.com

Imprint

In the course of improvement and adaptation to the state of the art, we reserve the right to make changes with regard to appearance, dimensions, weights and properties, and performance.

This does not imply any claim to correction or subsequent delivery of already delivered products. Deletions can be made at any time without any legal claim arising.

Instructions for use and safety are not binding. They never substitute for any legal or trade association regulations.

We do not accept any liability for printing errors.

Any reproduction, in whole or in part, requires the prior written consent of **GEDORE Automotive GmbH**.

All rights reserved worldwide. © Copyright by **GEDORE Automotive GmbH**, Donaueschingen (GERMANY)

We refer to our general terms and conditions which
can be found in the imprint at:

www.gedore-automotive.com



CONTENTS

1. READ AND UNDERSTAND FOR YOUR SAFETY	4
1.1 Target group.....	4
1.2 Obligations of the owner.....	4
1.3 Intended use	4
1.4 Reasonably foreseeable misuse	4
1.5 Personal protective equipment.....	4
1.6 Basic safety instructions	5
1.7 Work environment	5
1.8 Care and storage	5
1.9 Repair	5
1.10 Environmentally friendly disposal.....	5
2. PRODUCT DESCRIPTION.....	6
2.1 KL-0186-91 EA - Injector extractor kit	6
2.2 KL-0186-95 K - Injector puller kit.....	6
2.3 Supplementary kits.....	7
2.4 Scope of delivery/spare parts overview	8
3. PREPARATION	9
3.1 Checking the scope of delivery	9
3.2 Assembling drive parts	9
3.3 Preparing the tool.....	9
4. EXAMPLE OF USE	10

1. READ AND UNDERSTAND FOR YOUR SAFETY



Read and understand these operating instructions **before using** the injector puller and observe all safety and warning instructions. Misuse can result in **DEATH** or **SEVERE INJURIES** ! These operating instructions for use are an integral part of the injector puller. Keep them at a safe place for future reference, and always pass them on to subsequent users of the injector puller. The injector puller complies with the recognised rules of technology as well as the relevant safety regulations.

1.1 Target group

These operating instructions are **exclusively** intended for skilled personnel in specialised motor vehicle workshops!

The injector puller **may only be** used by skilled personnel in specialised motor vehicle workshops who are familiar with the basic regulations on work safety and accident prevention.

▼ **Never** allow unauthorised, inexperienced persons, minors and children, or persons with limited physical, sensory, and mental abilities to use the injector puller!

1.2 Obligations of the owner

Pursuant to the German Ordinance on Industrial Safety and Health (*BetrSichV*), employers are obliged to provide their employees with safe work equipment in accordance with the recognised rules of technology and the relevant safety regulations!

▼ The owner of the injector puller **must** ensure that **only** trained personnel in specialised vehicle workshops use the injector puller.

▼ The owner of the injector puller **must** ensure that the instructions for use are available to the user and that the user has completely read and understood the instructions for use **before** using the injector puller.

▼ The owner of the injector puller **must** ensure that the user is familiar with the basic regulations on work safety and accident prevention and that the personal protective equipment is available to him.

1.3 Intended use

The injector puller ...

▼ **may only** be used for the removal of injectors.

▼ **may only** be used on vehicles as specified in **Chapter 2. - Product description!**

▼ **may only** be used together with an approved drive!

▼ **may only** be used in the way described in these instructions for use.

▲ Any other use may result in **INJURY** !

1.4 Reasonably foreseeable misuse

The injector puller ...

▼ **must never** be used for the installation of injector.

▼ **must never** be used for the removal of axle parts.

▼ **must never** be used together with a non-approved drive.

▼ **must never** be modified, converted, or used for other purposes without authorisation.

▲ **Always** use the injector puller as intended, any other use may result in **INJURY** .

1.5 Personal protective equipment

For your safety, **always** wear personal protective equipment when using the injector puller!



Always wear **EYE PROTECTION** (for example to DIN EN 166, OSHA 29 CFR 1910.133, ANSI Z87) when using the injector puller to protect yourself against flinging parts or particles!



Always wear **PROTECTIVE GLOVES** (for example to DIN EN 388, OSHA 29 CFR 1910.138, ANSI 105) when using the injector puller to protect yourself against sharp edges and crushing between parts!



Always wear **SAFETY SHOES** (for example to DIN EN ISO 20345, OSHA 29 CFR 1910.136, ANSI Z41) when using the injector puller to protect yourself against falling parts!

1.6 Basic safety instructions

For your safety, **always** observe the following safety precautions when using the injector puller in order to avoid injuries and material damage caused by misuse or unsafe handling.

- ✔ Read and understand these instructions for use **before using** the special tool and observe all safety instructions for **safe use!**
- ✔ **Always** observe the vehicle-specific application procedures in the vehicle manufacturer's repair guide!
- ✔ **Always** work with the injector puller in accordance with the basic regulations on work safety and accident prevention!
- ✔ **Never** use the injector puller when you are tired or under the influence of alcohol, drugs, or medication!
- ✔ **Before each use**, check the injector puller **carefully** for damage, loose parts, or unauthorised modifications. **Never** use it if you notice any such deficiencies!
- ✔ Use **only genuine GEDORE Automotive** spare parts and accessories!
- ✔ **Before using** the injector puller, make sure that **no** unauthorised persons are in the immediate environment!
- ✔ **Never** use the injector puller with an unauthorised drive. Drive it **only** with an approved drive!
- ✔ **Always** wear your personal protective equipment (*safety goggles, protective gloves, safety shoes*) during work!
- ✔ Interrupt your work **immediately** if you are unsure about using the injector puller, and contact **GEDORE Automotive GmbH if necessary!**
- ✔ **Always** use the injector instructor as intended. Non-compliance will invalidate any warranty claim and may significantly reduce its durability!

1.7 Work environment

For your safety, **only** use the injector puller in a safe working environment.

- ✔ The workplace **must** be clean and tidy.
- ✔ The workplace **must** be sufficiently large and illuminated.
- ✔ The workplace **must** be on a solid and non-skidding floor.
- ✔ The workplace **must** be safeguarded against access of unauthorised persons.
- ✔ The workplace **must** be at room temperature between -10°C and +40°C.

1.8 Care and storage

Improper care and storage can damage the injector puller. Never use cleaning agents to clean the injector puller. This could destroy the device. After use, clean all parts only with a dry and clean cleaning cloth. Never immerse the injector puller in water, solvents, or cleaning liquids. To protect them against corrosion, lightly rub all metal parts after use with an anti-corrosion oil or wax that is suitable for tool care. Store the injector puller and the operating instructions in the packaging at a dry and clean place.

1.9 Repair

Do no longer use the injector puller if you notice signs of damage on it! A professional inspection and repair must only be carried out by specially trained specialists from GEDORE Automotive GmbH. Improper repair to the injector puller may result in **INJURY**.

1.10 Environmentally friendly disposal

Dispose of the injector puller and the packaging material in an environmentally compatible way in accordance with the legal requirements. If necessary, ask your local authorities about environmentally friendly disposal options.

2. Product description

2.1 KL-0186-91 EA - Injector puller kit, in foam insert

Fits universally for Denso injectors with a fuel connection with external thread M12x1.5 / 30° as well as for Bosch and Siemens/VDO injectors with a removable fuel connection with an internal thread M12x1 / 45°. For example, installed on VW-Audi, Seat, Škoda, BMW, Mercedes, Chrysler, Chevrolet, Citroën, Fiat, Hyundai, Iveco, Lancia, Opel, PSA, Peugeot, Renault, Saab, Suzuki, Toyota. Especially suitable for VW-Audi, Seat, Škoda (CFHA, CFJA, CFFB, CAYC); BMW (M47 / M57); Mercedes (OM611, OM612, OM613, OM646, OM647, OM648), and PSA (DW10).

For quick and professional extraction of tight-fitting injectors. Required when replacing the injectors or removing the valve cover, for example. Opening the injector is not necessary for this purpose as the injector puller is fastened with the fuel connection by means of the special screws included in the kit. The special design of the adapters and the joint piece included in the scope of delivery ensure damage-free and straight-line power transmission to the injector.

Recommended accessories: Cleaning tool - KL-0186-53 K

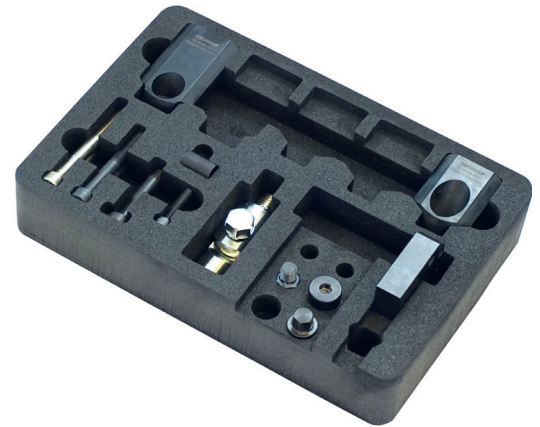

2.2 KL-0186-95 K - Injector puller kit (VM-Motori / HATZ-Diesel / Iveco)

Universally fits agricultural machines, construction machines, and municipal vehicles with engines from VM-Motori as well as HATZ-Diesel and Iveco. For example, the motor series: VM-Motori R754 (Euro 5 + Euro 6), R756 (Euro 6); HATZ-Diesel H-Series 3H50 TIC, 4H50 TIC; Iveco F1CE3 (Euro 5), 8140.43 (Euro 3). For example, installed on Aebi, Boki, Boschung, Bulmor, Bucher, Hako, Hansa, Kärcher, Ladog, Lindner, Meili, MFH, Reform, Schell, Schmidt, Trilety.

For quick and professional extraction of tight-fitting injectors. Required, for example, when replacing the injectors or removing the valve cover. Opening the injector is not necessary for this purpose as the injector extractor is fastened with the fuel connection by means of the special screws included in the kit. The special design of the adapters and the joint piece included in the scope of delivery ensure damage-free and straight-line power transmission to the injector.

Recommended accessories: Cleaning tool - KL-0186-53 K



2.3 Supplementary kits

For quick and easy pulling of tight-fitting injectors, in combination with the injector puller kit **KL-0186-91 EA** and an impact puller with M18x2.5 mounting thread. For example **KL-0369-4100** (1.5kg) or **KL-0049-300** (4.8kg). Required, for example, when removing the valve cover or replacing the injection nozzles.

KL-0186-9000 A - Nozzle puller base plate M18x2.5

For quick and professional pulling of tight-fitting injectors in combination with an impact puller with M18x2.5 mounting thread, e.g. **KL-0369-4100 (1.5kg)** or **KL-0049-300 (4.8kg)** (*accessories*), and a corresponding supplementary kit (e.g. **KL-0186-9001 A**, **KL-0186-9101 A**, **KL-0186-9201 A**, **KL-0186-9301**, **KL-0186-9401**). Required, for example, when replacing the injectors or removing the valve cover.

KL-0186-9001 A - Supplementary kit Bosch and Siemens-VDO, M12x1 / M12x1.5 / 45°

Universally fits Bosch and Siemens-VDO injectors with a removable fuel connection with M12x1 and M12x1.5 internal thread (45° angled).

For example, installed on BMW, Mercedes, Chrysler, Citroen, Fiat, Hyundai, Iveco, Lancia, Opel/Vauxhall, PSA, Peugeot, Renault, Suzuki.

Especially suitable for VW-Audi, Seat, Škoda (CFHA, CFJA, CFFB, CAYC); BMW (M47 / M57); Mercedes (OM611, OM612, OM613, OM646, OM647, OM648), and PSA (DW10).

KL-0186-9101 A - Supplementary kit Bosch M14x1.5 / 45°

Universally fits Bosch injectors with a detachable fuel connection with M14x1 and M14x1.5 internal thread (45° angled). Installed e.g. in VW-Audi, Seat, Škoda, Citroën, Fiat, Iveco, PSA, Peugeot. Especially suitable for Fiat Ducato, IVECO Daily 2.8 JTD; VW Golf 6, Tiguan, Touran 2.0 TDI (engine code CFFB); HATZ diesel H-series 3H50 TIC, 4H50 TIC industrial engines.

KL-0186-9201 A - Supplementary kit Denso M14x1.5 / 30°

Universally suitable for Denso injectors with a fuel connection with external thread M12x1.5 (30° angled).

Installed, for example, on Chevrolet, Opel/Vauxhall, Renault, Saab, Toyota.

KL-0186-9301 - Supplementary kit Denso M14x1.5 / 30°

Universal fit for Denso injectors with a fuel connection with an external thread M14x1.5 (30° angle). For example, installed on Opel and engines by VM-Motori R754 (Euro 5 + Euro 6), R756 (Euro 6).

KL-0186-9401 - Supplementary kit M12x1 / 20°

Universally fits Bosch and Siemens/VDO injectors with a removable fuel connection with M12x1 internal thread (20° angled). For example, installed on Citroën, Ford, Jaguar, PSA, Peugeot.

2.4 Scope of delivery / overview of the single parts

Injector puller modular system

Basic tool:	Item	Injector puller kits		Basic tool KL-0186-9000 A	Supplementary kits					
		KL-0186-91 EA	KL-0186-95 K		KL-0186-9001 A	KL-0186-9101 A	KL-0186-9201 A	KL-0186-9301	KL-0186-9401	
KL-0186-950 - Draw joint M18	A1	●								
KL-0186-9000-1 Base plate M18x2.5	A2	●	●	●						
KL-0186-9000-2 Cap screw M8x35	A3	●2x	●2x	●2x						
KL-0186-9000-3 Cap screw M10x75	A4	●2x	●2x		●2x					
KL-0186-9000-4 Cap screw M10x90	A5	●2x	●2x			●2x				
Adapter plates:										
KL-0186-9001-1 - Adapter plate M12x1 / 45°	B1	●			●					
KL-0186-9101-1 - Adapter plate M14x1.5 / 45°	B2		●			●				
KL-0186-9201-1 - Adapter plate Denso M12x1.5 / 30°	B3	●					●			
KL-0186-9301-1 - Adapter plate Denso M14x1.5 / 30°	B4		●					●		
KL-0186-9401-1 - Adapter plate M12x1 / 20°	B5								●	
Special screws and threaded sleeves:										
KL-0186-9001-2 - Special screw M12x1	C1	●			●				●	
KL-0186-9001-3 - Special screw M12x1 long	C2	●			●				●	
KL-0186-9001-4 - Sleeve	C3	●			●				●	
KL-0186-9001-5 - Adapter M12x1 / M12x1.5	C4	●	●		●					
KL-0186-9101-2 - Special screw M14x1.5	C5					●				
KL-0186-9101-3 - Special screw M14x1	C6		●			●				
KL-0186-9201-2 - Threaded sleeve M12x1.5	C7	●	●				●			
KL-0186-9301-2 - Threaded sleeve M14x1.5	C8							●		
Storage Systems:										
KL-0186-9090-2 A - Foam insert	-	●								
KL-4990-9324 - Plastic case	-	(Accessories)								
KL-0186-9090 - Plastic case	-		●							

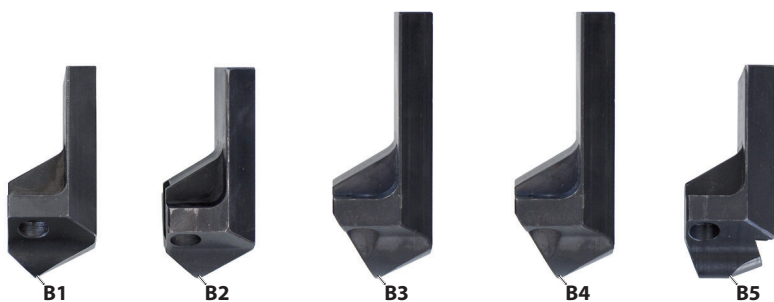
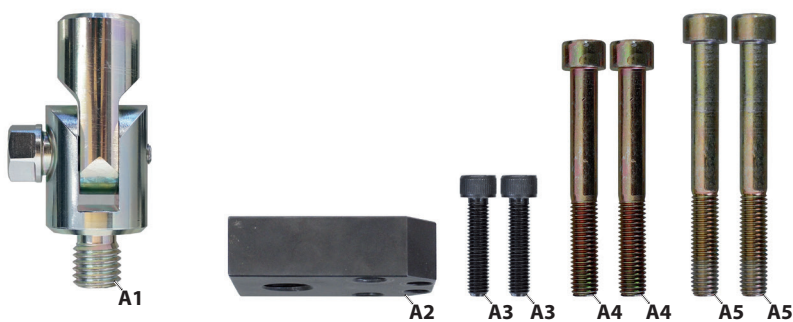

i This overview shows the entire modular system. The single components can be combined individually depending on the injector.



📷 1: Assemble the required drive parts.

KL-0369-4100
Impact puller

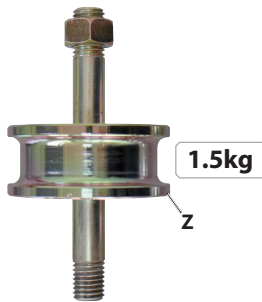

KL-0049-300
Impact extractor

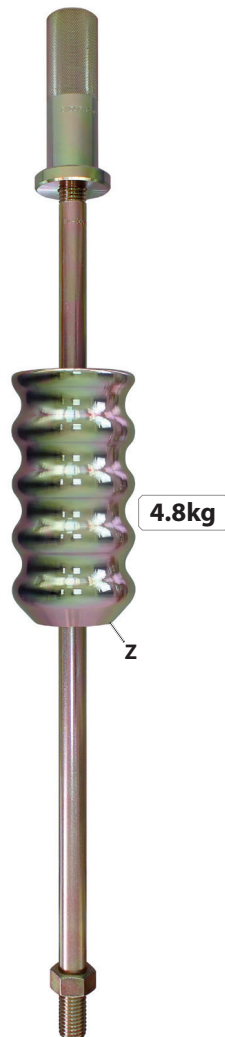

📷 2: Screw adapter plate [B..] on base plate [A2].

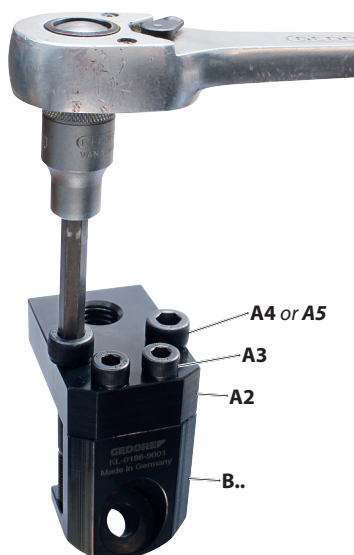

3. PREPARATION

- ▀ **Prior to using** the injector instructor, read and understand **all** safety instructions in **Chapter 1** and **always observe** them **for safe use!**
- ▀ Use the injector puller **only** as described in these operating instructions, and always observe the vehicle manufacturer's specifications!
- ▀ **Before each use**, check the injector puller **carefully** for damage, loose parts, or unauthorised modifications. **Never** use it if you notice any such deficiencies!
- ▀ **Always** wear your personal protective equipment (*safety goggles, protective gloves, safety shoes*) during work!

3.1 Checking the scope of delivery

Before using the injector puller, check that all the parts included in the scope of delivery (*see chapter 2.*) are present, and follow the instructions below.

3.2 Assembling drive parts

1. Assemble the required drive parts for the injector puller as shown in 📷 1.
- 📷 For other pressure plates see the *GEDORE Automotive catalogue*.

3.3 Preparing the tool

1. Depending on the injector design, assemble the required parts as in **Table 1**, corresponding to the injector puller.

CAUTION

The injector puller may be damaged!

- ▀ Observe the tightening torques of the cylinder screws [A3] + [A4] or [A5]!
- 2) Screw the base plate [A2] to the selected adapter plate [B..] using the cap screws [A3] + [A4] or [A5]. 📷 2
- 📷 Tighten the cap screws [A3] + [A4] or [A5] to **20Nm**.

Table 1:

Depending on the injector, assemble the required parts accordingly.

	BOSCH, SIEMENS/VDO	BOSCH, SIEMENS/VDO	BOSCH	DENSO	DENSO
	M12x1 / ~45° internal thread	M12x1 / ~20° internal thread	M14x1.5 / ~45° internal thread	M12x1.5 / ~30° internal or external thread	M14x1 / ~30° external thread
Basic tool:	Pos.				
KL-0186-950 - Draw joint M18	A1	●*	●*	●*	●*
KL-0186-9000-1 Base plate M18x2.5	A2	●	●	●	●
KL-0186-9000-2 Cap screw M8x35	A3	●2x	●2x	●2x	●2x
KL-0186-9000-3 Cap screw M10x75	A4	●2x	●2x	●2x	●2x
KL-0186-9000-4 Cap screw M10x90	A5			●2x	●2x
Adapter plates:					
KL-0186-9001-1 - Adapter plate M12x1 / 45°	B1	●			
KL-0186-9101-1 - Adapter plate M14x1.5 / 45°	B2		●		
KL-0186-9201-1 - Adapter plate Denso M12x1.5 / 30°	B3			●	
KL-0186-9301-1 - Adapter plate Denso M14x1.5 / 30°	B4				●
KL-0186-9401-1 - Adapter plate M12x1 / 20°	B5		●		
Special screws and threaded sleeves:					
KL-0186-9001-2 - Special screw M12x1	C1	●	●		
KL-0186-9001-3 - Special screw M12x1 long	C2	●**	●**		
KL-0186-9001-4 - Sleeve	C3	●**	●**		
KL-0186-9001-5 - Adapter M12x1 / M12x1.5	C4			●***	
KL-0186-9101-2 - Special screw M14x1.5	C5		●***		
KL-0186-9101-3 - Special screw M14x1	C6		●***		
KL-0186-9201-2 - Threaded sleeve M12x1.5	C7			●***	
KL-0186-9301-2 - Threaded sleeve M14x1.5	C8				●

●* = If required, use for straight power transmission. / ●** = Use for deep-seated injectors. / ●*** = Depending on thread.

Fig. 3: Depending on the injector, unscrew the fuel connection.

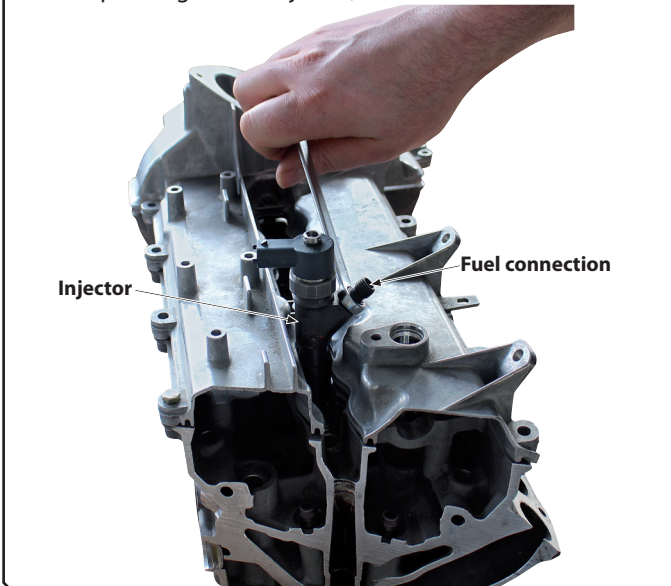

4. TYPICAL APPLICATION

This typical application describes the extraction of a tight-fitting injector using the impact puller which is available as an accessory - **KL-0369-4100**. The extraction with another impact puller is basically made according to the same principle.

CAUTION

The injector may be damaged.

- Always keep the fuel connection on the injector clean and avoid contamination.
- When removing the fuel connection, make sure that the sealing ring behind it is not lost.

1. Depending on the injector (for example BOSCH and SIEMENS-VDO), first unscrew the fuel connection completely and put it aside. **Fig. 3**

📷4: Mount the injector puller on the injector.

Possibility 1

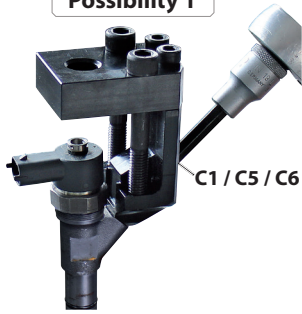

Possibility 2

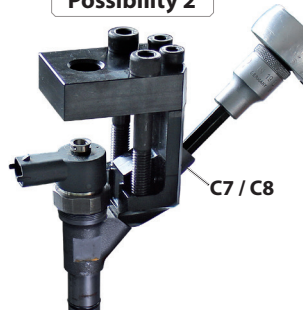

Possibility 3

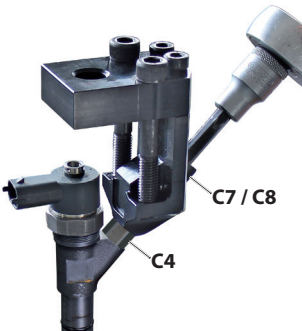

Possibility 4

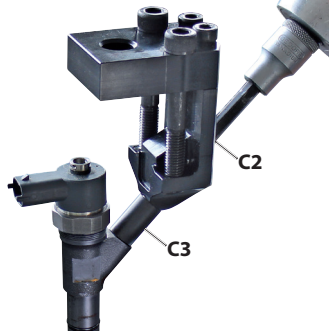

📷5: Insert the impact puller [Z] (and optionally the draw joint [A1]) into the base plate [A2].

A

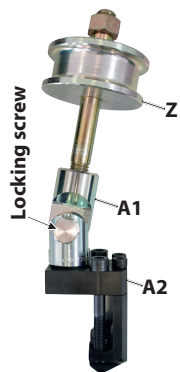

B

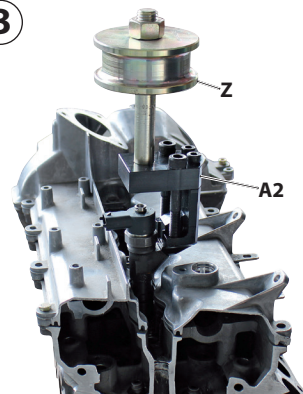

📷6: Remove the injector by pulling.

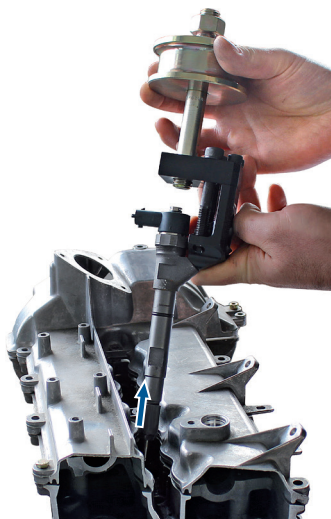

2. Use the appropriate special screw or threaded sleeve [C..] and screw the injector puller to the injector. **📷4**

If required by the position of the connector plug on the injector, **one of** the two cap screws [A4] or [A5] on the injector puller can be removed.

ⓘ Make sure that the injector puller is aligned straight to the injector.

Fasten the special screw or threaded sleeve [C..] to **20Nm**.

CAUTION

The injector may be damaged.

▼ The injector must always be pulled out as straight as possible! If necessary, also use the adjustable draw joint [A1] for exact compensation.

3) Screw the impact puller [Z] (and optionally the draw joint [A1]) as shown in **📷5A + B** completely into the base plate [A2].

ⓘ After alignment, fix the draw joint [A1] using the set screw.

📷5A

4) Then remove the injector from the cylinder head using the impact puller [Z]. **📷6**

🧑 Expert's tip:

🧑 Treat severely tight fitting injectors with rust remover first and let it soak in overnight.

ⓘ Before reinserting an injector, it is necessary to clean the hole in the cylinder head, for example with the cleaning tool - **KL-0186-53 K** - which is available as an *accessory*.

5. Remove the injector puller and continue the work according to the vehicle manufacturer's instructions.

GEDORE-Werkzeugfabrik GmbH & Co. KG

Remscheider Straße 149
42899 - Remscheid
Postfach 120361
47873 Remscheid
GERMANY

Vertrieb DEUTSCHLAND

☎ +49 (0) 2191 / 596-0
☎ +49 (0) 2191 / 596-230
✉ info@gedore.com
🌐 www.gedore.com

Sales INTERNATIONAL

☎ +49 (0) 2191 / 596-910
☎ +49 (0) 2191 / 596-911
✉ info@gedore.com
🌐 www.gedore.com

GEDORE TOOLS, INC.

Only for USA, Canada & Mexico
Sólo para EE.UU., Canadá y México
Seulement pour les USA, le Canada et le Mexique
7187 Bryhawke Circle, Suite 700, North Charleston, SC 29418, USA

☎ +1-843 / 225 50 15
☎ +1-843 / 225 50 20
✉ info@gedoretools.com
🌐 www.gedoretools.com

Worldwide GEDORE service centers and offices are listed on the Internet at: www.gedore.com

GEDORE Automotive GmbH

Breslauer Straße 41
78166 - Donaueschingen
Postfach 1329
78154 Donaueschingen
GERMANY

Vertrieb DEUTSCHLAND

☎ +49 (0) 771 / 8 32 23-0
☎ +49 (0) 771 / 8 32 23-90
✉ info.gam@gedore.com
🌐 gedore-automotive.com



www.gedore-automotive.com