



HSS-G SUPER DIN 338 RN

STEEL DRILL BIT

High-quality drill bit for alloyed and unalloyed steels











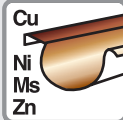

PRODUCT DESCRIPTION

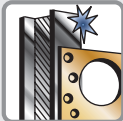
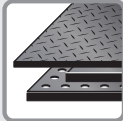





- High precision and durable with best grinding in metal
- Precision Drilling according to DIN 338 RN for outstanding dimensional accuracy of the hole
- Split point grinding and 135° point angle for optimum centring during drilling
- Excellent concentricity according to DIN 1414









Website info





Product group 0900	 CYL	Diameter 1–14 mm			
PROFESSIONAL	 Rotary drilling				



				
17760 3	1	12	34	2
17761 0	1.5	18	40	2
17762 7	2	24	49	2
17763 4	2.5	30	57	2
17764 1	3	33	61	2
17765 8	3.2	36	65	2
17766 5	3.3	36	65	2
17767 2	3.5	39	70	2
17768 9	4	43	75	1
17769 6	4.2	43	75	1
17770 2	4.5	47	80	1
17771 9	4.8	52	86	1
17772 6	5	52	86	1
17773 3	5.5	57	93	1
17774 0	6	57	93	1
17775 7	6.5	63	101	1
17776 4	7	69	109	1
17777 1	7.5	69	109	1
17778 8	8	75	117	1
17779 5	8.5	75	117	1
17780 1	9	81	125	1
17781 8	9.5	81	125	1
17782 5	10	87	133	1
17783 2	10.5	87	133	1
17784 9	11	94	142	1
17785 6	11.5	94	142	1
17786 3	12	101	151	1
17787 0	12.5	101	151	1
17788 7	13	101	151	1

					
21121 5	1	-	12	34	10
21122 2	1.1	-	14	36	10
21123 9	1.2	-	16	38	10
21124 6	1.3	-	16	38	10
21125 3	1.4	-	18	40	10
21126 0	1.5	-	18	40	10
21127 7	1.6	M2	20	47	10
21128 4	1.7	-	20	43	10
21129 1	1.8	-	22	46	10
21130 7	1.9	-	22	46	10
21131 4	2	-	24	49	10
21132 1	2.1	-	24	49	10
21133 8	2.2	-	27	53	10
21134 5	2.3	-	27	53	10
21135 2	2.4	-	30	57	10
21136 9	2.5	M3	30	57	10
21137 6	2.6	-	30	57	10
21138 3	2.7	-	33	61	10
21139 0	2.8	-	33	61	10
21140 6	2.9	-	33	61	10
21141 3	3	-	33	61	10
21142 0	3.1	-	36	65	10
21143 7	3.2	-	36	65	10
21144 4	3.3	M4	36	65	10
21145 1	3.4	-	39	70	10
21146 8	3.5	-	39	70	10
21147 5	3.6	-	39	70	10
21148 2	3.7	-	39	70	10
21149 9	3.8	-	43	75	10
21150 5	3.9	-	43	75	10
21151 2	4	-	43	75	10
21152 9	4.1	-	43	75	10
21153 6	4.2	M5	43	75	10
21154 3	4.3	-	47	80	10
21155 0	4.4	-	47	80	10
21156 7	4.5	-	47	80	10
21157 4	4.6	-	47	80	10
21158 1	4.7	-	47	80	10
21159 8	4.8	-	52	86	10
21160 4	4.9	-	52	86	10
21161 1	5	M6	52	86	10



MULTIPACK

					
23022 3	0.2	-	3	19	10
23023 0	0.3	-	3	19	10
23024 7	0.4	-	5	20	10
23025 4	0.5	-	6	22	10
23026 1	0.6	-	7	24	10
23027 8	0.7	-	9	28	10
23028 5	0.8	M1	10	30	10
23029 2	0.9	-	11	32	10

Art. 4010159-					
21162 8	5.1	-	52	86	10
21163 5	5.2	-	52	86	10
21164 2	5.3	-	52	86	10
21165 9	5.4	-	57	93	10
21166 6	5.5	-	57	93	10
21167 3	5.6	-	57	86	10
21168 0	5.7	-	57	93	10
21169 7	5.8	-	57	93	10
21170 3	5.9	-	57	93	10
21171 0	6	M7	57	93	10
21172 7	6.1	-	63	101	10
21173 4	6.2	-	63	101	10
21174 1	6.3	-	63	101	10
21175 8	6.4	-	63	101	10
21176 5	6.5	-	63	101	10
21177 2	6.6	-	63	101	10
21178 9	6.7	-	63	101	10
21179 6	6.8	M8	69	109	10
21180 2	6.9	-	69	109	10
21181 9	7	-	69	109	10
21182 6	7.1	-	69	109	10
21183 3	7.2	-	69	109	10
21184 0	7.3	-	69	109	10
21185 7	7.4	-	69	109	10
21186 4	7.5	-	69	109	10
21187 1	7.6	-	75	117	10
21188 8	7.7	-	75	117	10
21189 5	7.8	M9	75	117	10
21190 1	7.9	-	75	117	10
21191 8	8	-	75	117	10
21192 5	8.1	-	75	117	10
21193 2	8.2	-	75	117	10
21194 9	8.3	-	75	117	10
21195 6	8.4	-	75	117	10
21196 3	8.5	M10	75	117	10
21197 0	8.6	-	81	125	10
21198 7	8.7	-	81	125	10
21199 4	8.8	-	81	125	10
21200 7	8.9	-	81	125	10
21201 4	9	-	81	125	10

Art. 4010159-					
21202 1	9.1	-	81	125	10
21203 8	9.2	-	81	125	10
21204 5	9.3	-	81	125	10
21205 2	9.4	-	81	125	10
21206 9	9.5	M11	81	125	10
21207 6	9.6	-	87	133	10
21208 3	9.7	-	87	133	10
21209 0	9.8	-	87	133	10
21210 6	9.9	-	87	133	10
21211 3	10	-	87	133	10
21212 0	10.2	M12	87	133	5
21213 7	10.5	-	87	133	5
21214 4	11	-	94	142	5
21216 8	11.5	-	94	142	5
21217 5	12	M14	101	151	5
21219 9	12.5	-	101	151	5
21220 5	13	-	101	151	5
25734 3	13.5	-	108	160	5
25736 7	14	M16	108	160	5

SETS

	Art. 4010159-			
*1	17731 3	Ø 2/3/4/5/6/8		6
*2	17733 7	Ø 2/2.5/3/3.5,,,7/7.5/8		13
*3	21961 7	Ø 1/1.5/2/2.5,,,9/9.5/10		19
*4	21964 8	Ø 1/1.5/2/2.5,,,12/12.5/13		25

