

C U T - O F F S A W

**HU 315 SK**

# TABLE OF CONTENTS

1.	General safety rules for all machines	3
2.	Additional safety rules	4
3.	Specification	4
4.	Outline Description	4
5.	Instruction of installation	6
5.1	Unpacking and Inspection	6
5.2	Lifting, Moving and Anchoring	6
5.3	Connecting Electric Power	6
5.4	Connecting Compressed Air Hose	6
5.5	Filling coolant	6
5.6	Procedure to install the stopper	6
5.7	Function of control devices	6
6.	Instruction of operation	7
6.1	Preparation for Operation	7
6.2	Steps of Operation	9
6.3	Daily Inspection and Maintenance	10
7.	Air-hydraulic system diagram	10

# HU 315 SK

## 1. GENERAL SAFETY RULES FOR ALL MACHINES

N.B.: Read the instructions carefully in order to avoid any problems.

As with all machinery there are certain hazards involved with operation and use of this machine. Using the machine with respect and caution will considerably lessen the possibility of personal injury. However, if normal safety precautions are overlooked or ignored, personal injury to the operator may occur. Observe these rules insofar as they are applicable to this particular machine.

This machine was designed for certain applications only. We strongly recommend that this machine NOT be modified in any way and/or used for any application other than for which it was designed.

If you have any questions relative to its application DO NOT use the machine until you have contacted your dealer.

1. For your own safety read the instruction manual before operating the tool.
2. Keep all guards in place and in working order.
3. Ground all tools.
4. Remove adjusting keys and wrenches. Make a habit of checking the machine before turning it on.
5. Keep the work area clean. Cluttered areas and benches invite accidents.
6. Do not use in a dangerous environment, such as damp or wet locations or expose to rain. Always keep the work area well-lit.
7. Keep children and visitors away. They must be kept at a safe distance from the machine at all times.
8. Make sure that the work area is not accessible to unauthorised persons. Use padlocks, master switches, remove starter keys etc.
9. Never overload the machine. The capacity of the machine is at its largest when properly loaded.
10. Do not force the machine or attachment to do a job for which it was not designed.
11. Wear proper apparel. No loose clothing, gloves, neckties, rings, necklaces, bracelets or jewellery: they may get caught in moving parts. No slip footwear is recommended. Wear a hairnet to contain long hair.
12. Always wear safety glasses and work according to safety regulations. Use a face or dust mask if operation is dusty.
13. Always secure workpiece tightly using a vise or clamping device. This will keep both hands free to operate the machine.
14. Do not overreach. Keep your proper footing and balance at all times.
15. Maintain tools in top condition. Keep them sharp and clean. Read the instructions carefully and follow the instructions for cleaning, lubrication and tool replacement.
16. Lubricate the machine and fill all oil reservoirs before operation.
17. Disconnect tools before servicing and when changing accessories such as blades, bits, cutters etc.
18. Use only recommended accessories. Consult the owner's manual for recommended accessories. The use of improper accessories may cause hazards.
19. Avoid accidental starting. Make sure the on/off switch is in the "OFF" position before plugging in the power cord.
20. Never stand on the machine or tools. Serious injury could occur if the machine is tipped or if the cutting tool is accidentally touched.
21. Check damaged parts. Replace or repair damaged parts immediately. Check machine for alignment of moving parts, binding of moving parts, breakage of parts, mounting and any other conditions that may affect its operation.
22. Direction of feed. Feed work into a blade or cutter against the direction of rotation of the blade or cutter only.
23. Never leave tool running unattended. Do not turn power off until it has come to a complete stop.
24. Alcohol, medication, drugs. Never use the machine while under the influence of alcohol, medication or drugs.
25. Make sure the tool is disconnected from the power supply, before servicing, repairing etc.
26. Keep the original packing for future transport or relocation of the machine.

## 2. ADDITIONAL SAFETY RULES

Always keep in mind that:

- the machine must be switched off and disconnected from the power supply during maintenance and repairs,
- clamped workpieces may only be measured when the machine is switched off.

Never lean over the machine, mind loose clothing, ties, jewellery etc. and wear a cap.

Do not remove safety devices or guards. Never use the machine while a guard is open.

Always use safety glasses for machining rough materials.

Burrs and chips should only be removed using a sweeper or other aid, never with your bare hands!

Never leave the machine running unattended.



**Always wear safety glasses!**

## 3. SPECIFICATION

Motor power	1 kW	Sawing capacity 90° rectangular	85 x 110 mm
Speed:	50/25 tr/min	Sawing capacity 90° round	100 mm
Angle:	45 L/R °	Sawing capacity 90° square	90 mm
Sawing capacity 45° rectangular	85 x 85 mm	Saw blade dimensions	315 mm
Sawing capacity 45° round	100 mm	Net weight	200 kg
Sawing capacity 45° square	85 mm	Voltage	400 V

## 4. OUTLINE DESCRIPTION

(1) Front view

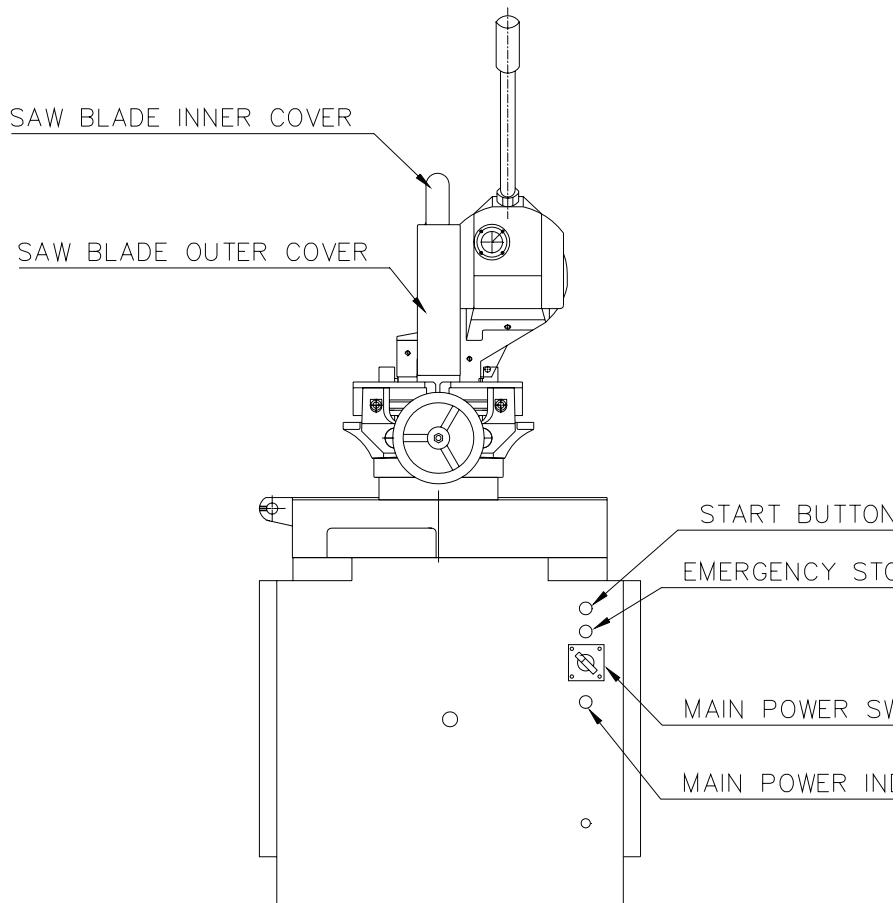

(2) Right side view

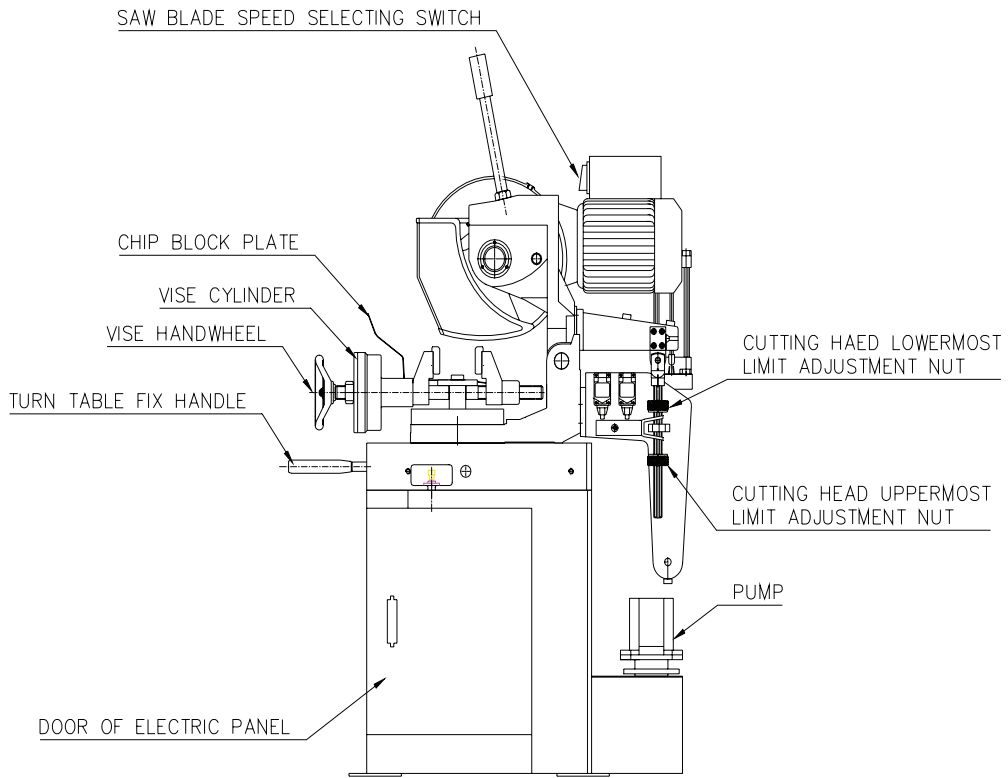

(3) Left side view

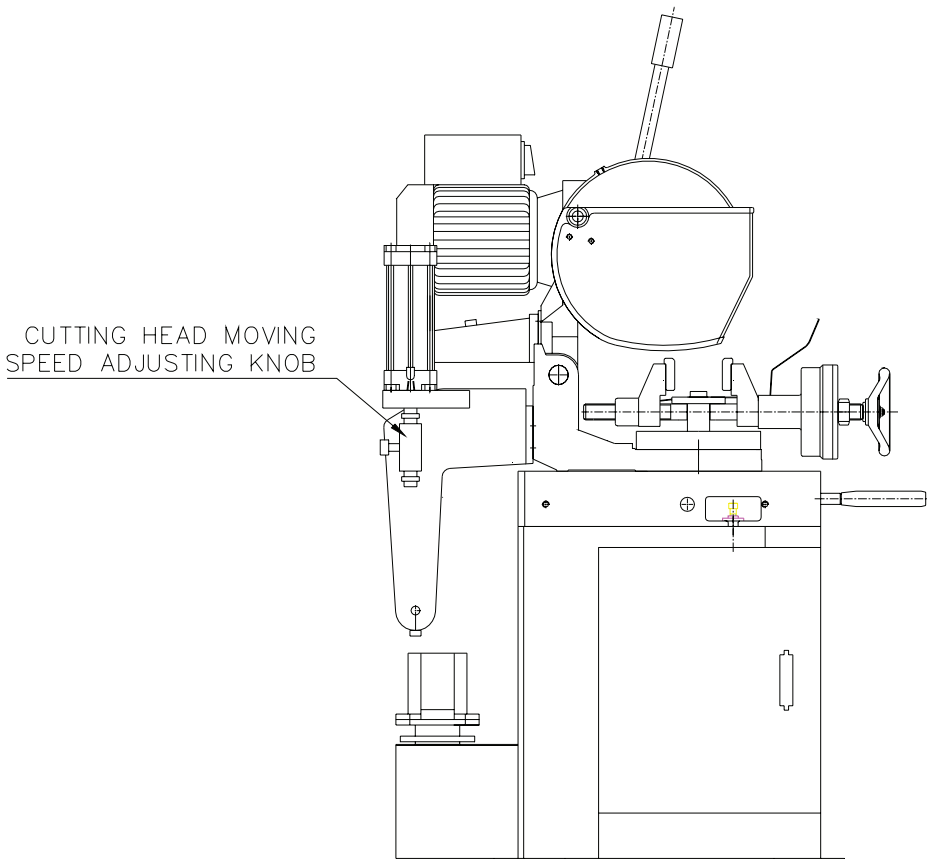

## 5. INSTRUCTION OF INSTALLATION

---

Note: Please read the instruction carefully before installation. If having any question please contact your dealer for prompt service

---

### 5.1 UNPACKING AND INSPECTION

- (1) Check if there is any damage on the wooden case or the plastic bag that used to pack the machine. Should any damage be found on the machine, please claim for the damage against the delivery or insurance company.
- (2) Check the machine and accessories against the packing list. Should any shortage, please contact your dealer.

### 5.2 LIFTING, MOVING AND ANCHORING

- (1) Lifting eyebolts have been mounted on the machine. Please use hoist and sling devices with enough capacity to lift and move the machine.
- (2) Slots, designed at the bottom of the machine, can be used by forklift to move the machine.
- (3) Please watch over the obstacle or personnel that may be on the way of moving the machine.
- (4) Place the machine on a horizontal foundation. Use anchor bolt and nut to fix the machine.

### 5.3 CONNECTING ELECTRIC POWER

---

Note:

- (1) Assure the main power switch is at "OFF" position and the saw blade motor speed select switch is at "OFF" position before connecting the machine to electric power source
  - (2) Do not install saw blade on the main shaft when checking the rotational direction of the main shaft.
- 

- (1) Only qualified electrician can connect electric power.
- (2) The voltage, amperage and protection capacity of the power source shall meet the requirement of the machine.
- (3) Check the rotation of the saw blade shaft (arbor). Change over two conductors in junction box if the direction of rotation does not consist with the direction of the label on the saw blade safety cover.

### 5.4 CONNECTING COMPRESSED AIR HOSE

- (1) Refer to Compressed Air System Diagram to connect proper compressed air.
- (2) Take an air hose to connect the air inlet at the back of machine.

### 5.5 FILLING COOLANT

- (1) Pour the diluted sawing oil on the table of the machine. The solution will flow into the coolant tank.
- (2) The dilute ratio (water: oil) is 5:1 for hard or high alloy steel and 10:1 for mild steel.

### 5.6 PROCEDURE TO INSTLL THE STOPPER

- (1) Mount the stopper arm at the "0" point on the stopper support beam as illustrated on following figure1.
- (2) Put the stopper support beam into the hole in the base plate.
- (3) Fix the stopper support beam when the stopper is just touching the sawblade as illustrated on following figure 2.

### 5.7 FUNCTION OF CONTROL DEVICES

#### (1) Main Power Switch

Main Power switch is an "ON-OFF" two-position lever switch to connect or disconnect outside power to the machine. Main (saw blade) motor runs when main power switch is at "ON" position.

#### (2) Main Power Indicator

Main power indicator lights up when main power switch is at "ON" position.

#### (3) Start Button

Press and release the start button to start the operation of the front vise cylinder, the saw blade motor and the

---

vertical action of cutting head. Press the button once to get one cutting cycle.

#### **(4) Emergency Stop Button**

Stop all the actions of Item (3) immediately when the button is pressed. Turn the button clockwise to reset.

#### **(5) Uppermost Limit Adjustment Nut and Lowermost Limit Adjustment Nut**

By adjusting the uppermost limit adjustment nut and lowermost limit adjustment nut to actuate the position limit switches and to control the stroke of saw blade.

#### **(6) Saw Blade Motor Speed Select Switch**

This is a "LOW-OFF-HI" three-position level switch on the top of the motor for selecting a suitable speed for saw blade to cut material.

#### **(7) Saw Blade Feeding (Cutting Head Moving) Speed Adjustment Knob**

By adjusting the flow rate of hydraulic oil to control the saw blade feeding speed.

## **6. INSTRUCTION OF OPERATION**

### **6.1 PREPARATION FOR OPERATION**

#### **6.1.1 Adjustment of the Clamping Vise**

(1) Turn the main power switch OFF.

(Cutting head shall be at upper position)

(Clamping vise shall be at open position)

(2) Turn the hand wheel of clamping vise counter-clockwise to open the vise.

(3) Put a work piece into the clamping area of vises.

(4) Turn the hand wheel of clamping vise clockwise to close the vise and fasten work piece.

(5) Turn the hand wheel of clamping vise 1/2 (half) turn counter-clockwise.

(6) Press and hold emergency stop button to check the tightness of work piece that fastened by the actuated air cylinder.

---

#### **NOTE:**

(1) If the work piece is deformed by the clamping action of vise, turn the hand wheel 1/4 turn counter-clockwise at a time and check it again.

(2) If the work piece is not fastened tightly enough, turn the hand wheel 1/4 turn clockwise at a time and check it again.

(3) Don't press start button. Avoid the cutting head going down.

---

#### **6.1.2 Installation of the Saw Blade**

(1) Turn the adjusting nut of uppermost limit to the highest position.

(2) Turn ON main power switch.

(3) Press start button. (Cutting head goes up to the highest position)

(4) Turn OFF main power switch.

(5) Open saw blade safety covers.

(6) Remove the clamping flange from the saw arbor.

(7) Clean the clamping surfaces of flange and arbor free from any dirt or chips.

(8) Clean the clamping area of the saw blade.

(9) Mount saw blade on the arbor. Align the pinholes of saw blade and arbor. Put the clamping flange on the saw blade, and tighten the center bolt.

---

**Note:** The rotation of saw blade shall be counter-clockwise while looking at the mounting surface. There is a directional mark labeled on the protection cover.

---

(10) When lock the center bolt, keep the front part of saw blade downward to eliminate the gap between pin and pinhole.

(11) Adjust the chip remover to the location that it is able to knock down chips.

(12) Close the saw blade safety covers.

---

**Note:** The following Charts of "Number of Saw Blade Tooth Selection" are for reference.

---

Number of Saw Blade Tooth (T) Selection for Mild Steel Tube Cutting					
Wall Thickness of Tube ( mm )	Diameter of Saw Blade ( mm )				Remark
	Φ250	Φ275	Φ300	Φ350	
0.6~0.8	T=280	280	300	320	For Tube Diameter $D \geq 10$ mm
0.8~1.0	240	280	280	320	
1.0~1.2	220	240	240	280	
1.2~1.6	200	220	240	240	
1.6~2.0	180	200	220	220	
2.0~2.5	150	180	180	200	$D \geq 15$ mm
2.5~3.5	120	150	150	180	$D \geq 20$ mm
3.5~4.5	90	120	120	150	$D \geq 25$ mm
4.5~5.5	80	80	90	120	$D \geq 30$ mm
5.5~7.0	64	64	80	90	$D \geq 40$ mm

For Wall Thickness  $\geq 2$  mm, the Formula for Number of Tooth T is as following

$$T = 2 \times (\text{Diameter of Saw Blade} \times 3.14) \div (\text{Wall Thickness of Tube})$$

Number of Saw Blade Tooth (T) Selection for Mild Steel Solid Bar Cutting					
Size of Bar ( mm )	Diameter of Saw Blade ( mm )				
	Φ250	Φ275	Φ300	Φ350	
6~10	T=180	200	200	220	
10~14	160	160	180	200	
14~18	150	160	160	180	
18~22	120	150	150	160	
22~28	90	90	120	160	
28~35	80	80	90	120	
35~45	70	70	80	90	
45~50	64	64	70	80	

For Size of Bar  $\geq 38$  mm, the Formula for Number of Tooth T is as following

$$T = 4 \times (\text{Diameter of Saw Blade} \times 3.14) \div (\text{Size of Bar})$$

1. For stainless steel, the number of tooth is one grade more than mild steel.
2. For aluminum and copper, the number of tooth is one grade less than mild steel.
3. For 45° miter cutting, the number of tooth is one grade less than 90° cutting.

### 6.1.3 Adjustment of the Saw blade Traveling Stroke

- (1) Turn the cutting head moving (saw blade feeding) speed adjustment knob clockwise to closed position.
- (2) Turn the saw blade speed-selecting switch to OFF position.
- (3) Turn the main power switch to ON position.
- (4) Press the start button.
- (5) Open the cutting head moving speed adjustment knob a little to let the saw blade downward slowly.
- (6) Entirely close the cutting head moving speed adjustment knob as the saw blade reach the expected lower position (work piece can just be cut off).
- (7) Adjust the lowermost limit adjustment nut to such a position that it can actuate the lowermost limit switch, which can stop the downward movement of cutting head.
- (8) Adjust the uppermost limit adjustment nut to such a position that the bottom tip of saw blade is higher than the top of work piece about 10~15 mm, and the uppermost limit switch can be actuated at that position.



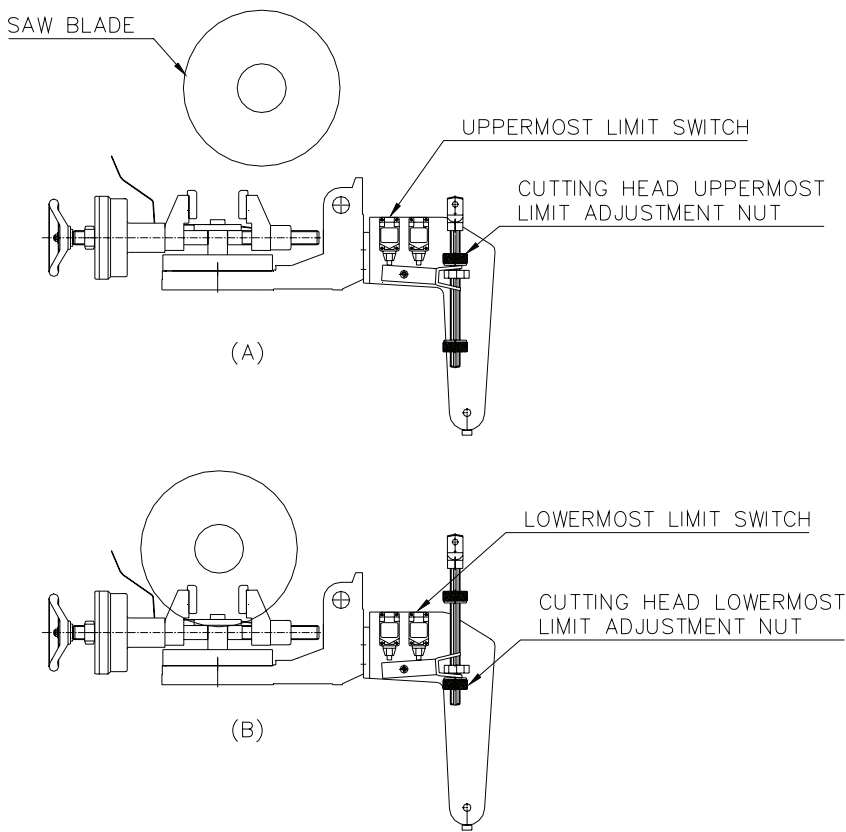

#### 6.1.4 Adjustment of the Saw Blade Rotating Speed

Turn the saw blade speed-selecting switch to one of "LOW", "HI" or "OFF" position.

#### 6.1.5 Adjustment of the Saw Blade Feeding Speed

Turn the cutting head moving (saw blade feeding) speed adjustment knob clockwise or counter-clockwise.

#### 6.1.6 Adjustment of the Cutting Angle

- (1) Push the turning table fixing handle leftward.
- (2) Turn the turning table to the required angle.
- (3) Push the fixing handle rightward.

### 6.2 STEPS OF OPERATION

- (1) Prepare the machine as states in Section 5.1.
- (2) Turn main switch ON.
- (3) Put a work piece into vise.
- (4) Press start button.
  1. Vise clamps work piece.
  2. Saw blade starts to rotate.
  3. Coolant starts to flow out of nozzle.
  4. Cutting head moves down.
  5. Saw blade cuts work piece.
  6. Cutting head moves up.
  7. Saw blade stops rotating.
  8. Vise releases work piece.
- (5) Repeat step (3) and (4).
- (6) Turn main switch off when finish.

---

**NOTE:** Press the emergency button immediately if any malfunction or abnormal situation happens.

---

## 6.3 DAILY INSPECTION AND MAINTENANCE

### 6.3.1 Gear Box of Cutting Head

- (1) Change gear oil SAE 140 every six months.
- (2) Check temperature of the gearbox during continuous operation.

### 6.3.2 Chip Collecting Tray

Remove chip from collecting tray.

## 7. AIR-HYDRAULIC SYSTEM DIAGRAM

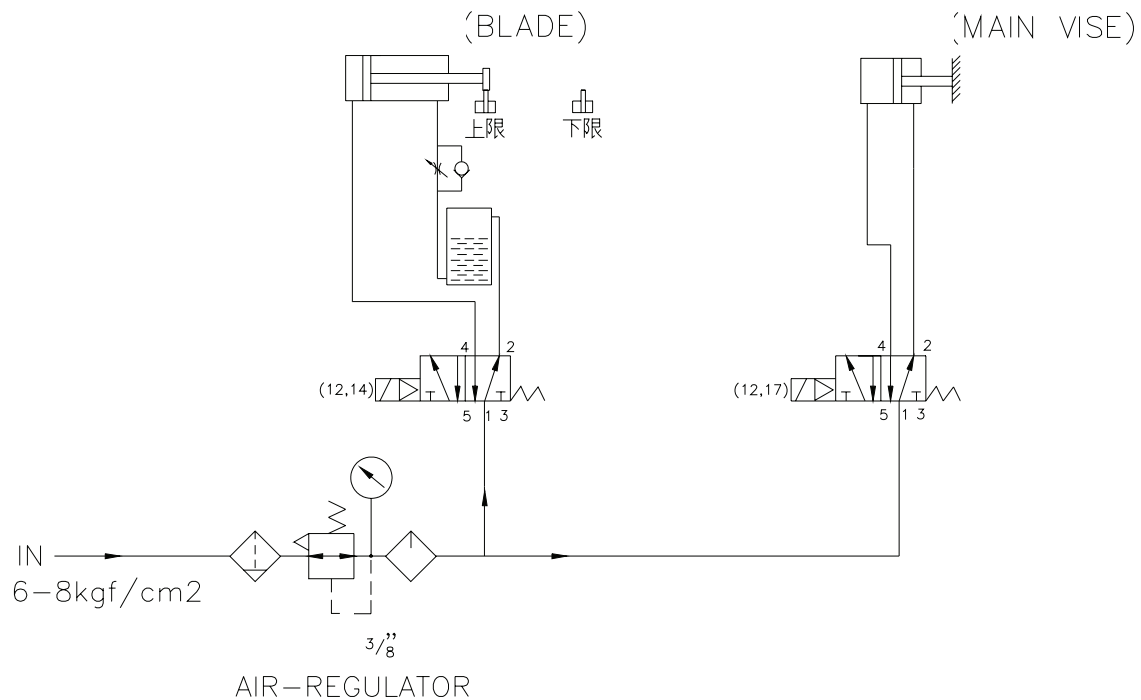

## 8. PARTS DRAWING AND LIST

- (1) Head and Spindle Shaft Assembly
- (2) Motor Assembly
- (3) Feeding Handle Assembly
- (4) Rotary Support Assembly
- (5) Vise Assembly
- (6) Table Assembly
- (7) Saw Blade Protective Cover and Safety Guard Assembly
- (8) Main Base Assembly-1 (with Electric Control)
- (9) Main Base Assembly-2 (Air Control System)
- (10) Main Base Assembly-3 (Cooling System)
- (11) Cylinder Assembly

# 9. ELECTRIC SCHEME

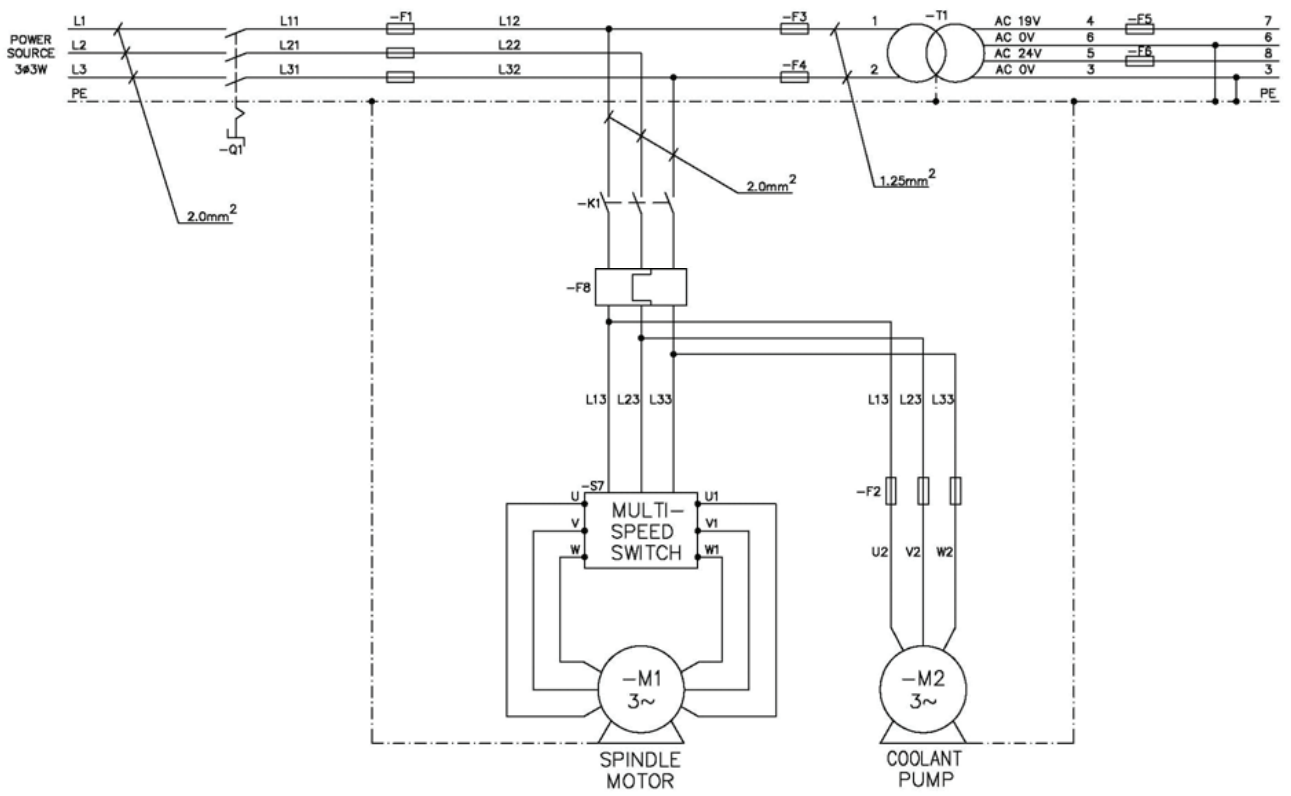

A

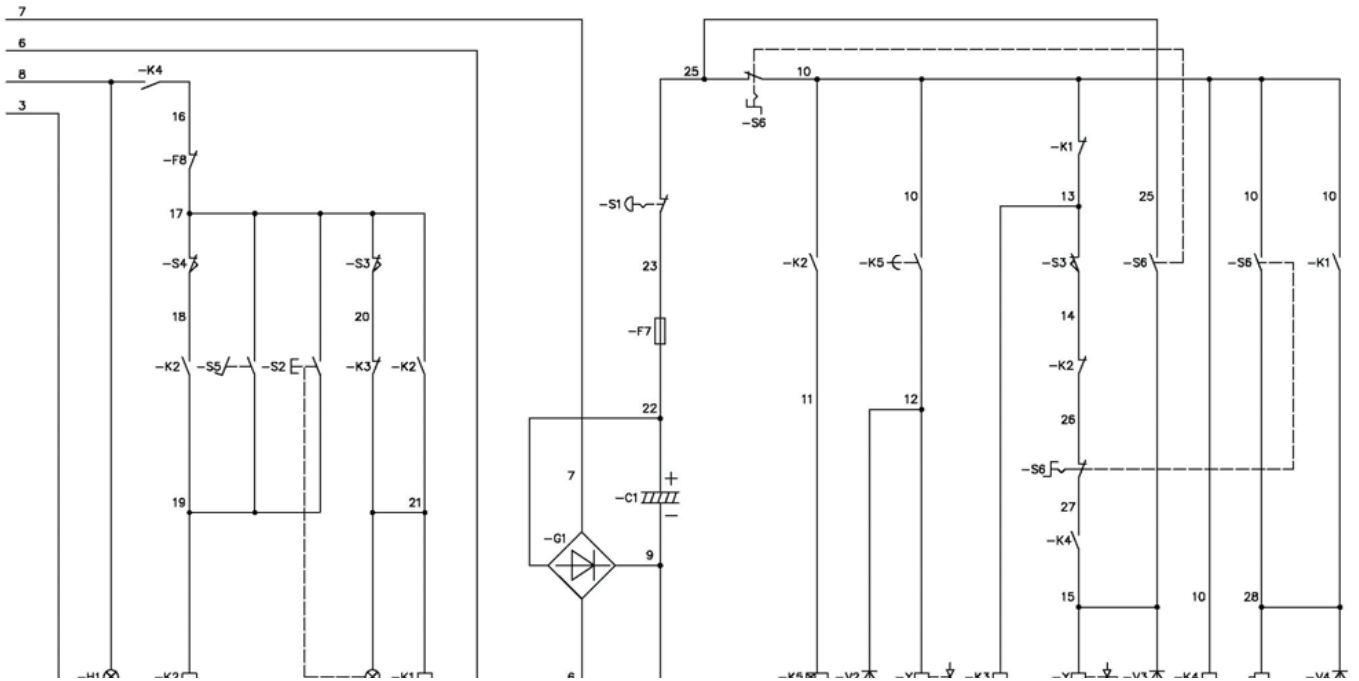

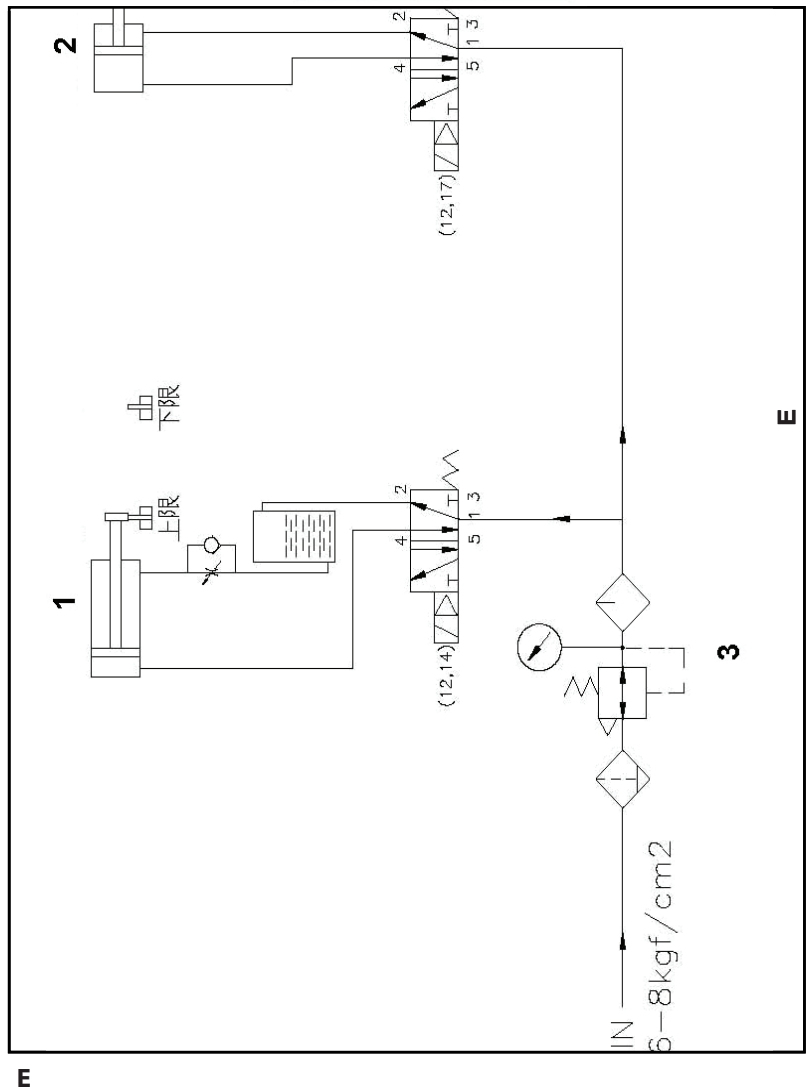
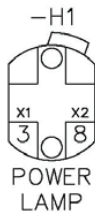
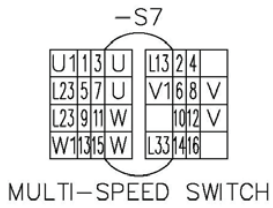
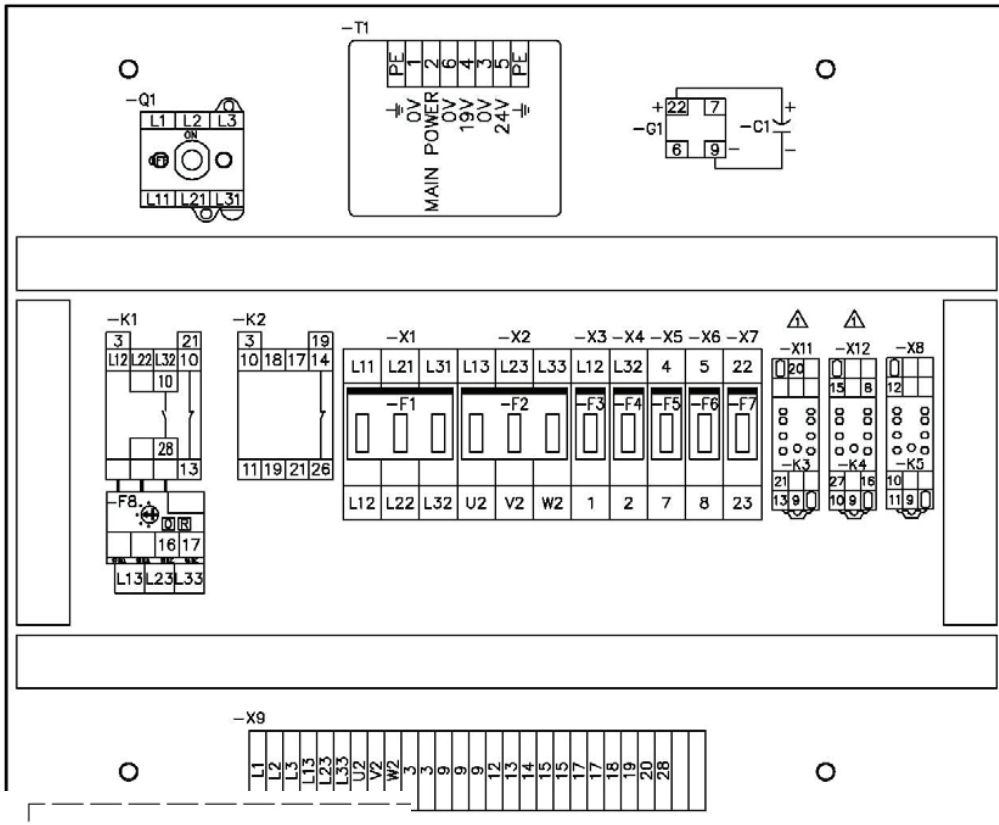

Our products are frequently updated and improved. Minor changes may not yet be incorporated in this manual. Always state the year of build, type and serial number of the machine in correspondence.

Manufacturer and importer assume no responsibility for defects which result from not reading the manual carefully or wrong use of the machine. No rights can be derived from this manual.

All rights reserved. No part of this booklet may be reproduced in any form, by print, photoprint, microfilm or any other means without written permission from the publisher.

© Huberts bv, Kennedylaan 14, Veghel, the Netherlands.

Internet: [www.huvema.nl](http://www.huvema.nl)

