

# S60LN15C

## PLANFRÄSER FÜR SCHWERE SCHRUPPANWENDUNGEN FACE MILLING CUTTERS FOR HEAVY ROUGHING

PLANFRÄSER  
FACE MILLING CUTTERS



ECKFRÄSER  
SHOULDER END MILLING CUTTERS

$\gamma_p$	+4°	$\kappa_r$	60°
$\gamma_f$	-12° – -13,5°	$a_{p \max}$	12 mm

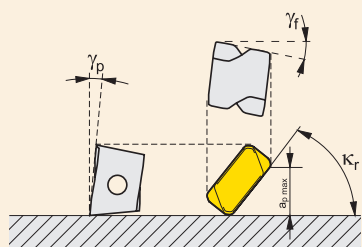

Abmessungen [mm]. / Dimensions [mm].

Z\* – Anzahl Zähne / Number of teeth

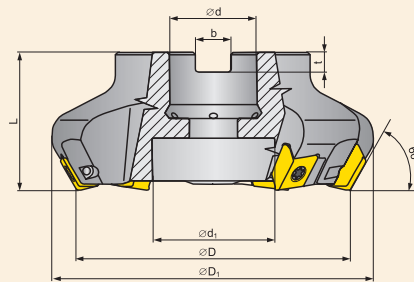

Ø 125 mm

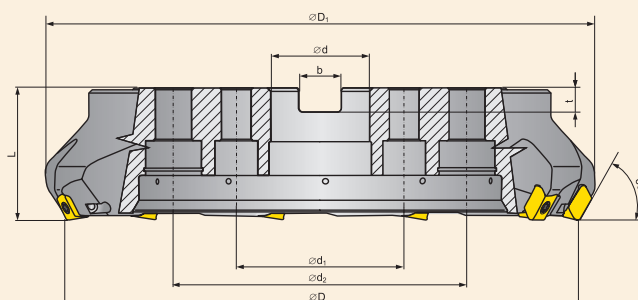

Ø 160 ÷ 315 mm

### ISO

#### Abmessungen / Dimensions

ISO	Sortiment / Assortment	D	D <sub>1</sub>	d	L	d <sub>1</sub>	d <sub>2</sub>	t	b	Z*	Kühlung Cooling	[kg]
125A06R-S60LN15C-C	●	125	147	40	63	56	-	9	16,4	6	+	4
160C08R-S60LN15C-C	●	160	181,6	40	63	66,7	-	9	16,4	8	+	6,10
200C08R-S60LN15C-C	●	200	221,6	60	63	101,6	-	14	25,7	8	+	9,40
200C10R-S60LN15C-C	●	200	221,6	60	63	101,6	-	14	25,7	10	+	9,40
250C09R-S60LN15C-C	●	250	269,6	60	63	101,6	-	14	25,7	9	+	15,60
250C12R-S60LN15C-C	●	250	269,6	60	63	101,6	-	14	25,7	12	+	15,90
315C11R-S60LN15C-C	●	315	333,9	60	80	101,6	177,8	14	25,7	11	+	31,50
315C14R-S60LN15C-C	●	315	333,9	60	80	101,6	177,8	14	25,7	14	+	31,90

FRÄSER FÜR SPEZ. ANWENDUNGEN  
CUTTERS FOR SPECIAL APPLICATION

WENDESCHNEIDPLATTEN  
INDEXABLE INSERTS

# S60LN15C

## PLANFRÄSER FÜR SCHWERE SCHRUPPANWENDUNGEN FACE MILLING CUTTERS FOR HEAVY ROUGHING

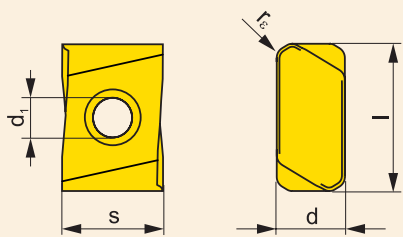

LNX 15



LNX 15-KR



LNX 15-M

### WENDESCHNEIDPLATTEN (WSP) / INDEXABLE CUTTING INSERTS

ISO	Materialien / Grades						Abmessungen / Dimensions				
	M5326	M8326	M8346				(l)	d	s	d <sub>1</sub>	r <sub>e</sub>
LNX 1513DPSR-M	●	●	●				20,750	9,600	14,3	5,7	1,6
LNX 1513DPSR-KR	●	●	●				20,750	9,600	13,6	5,7	1,6

### ERSATZTEILE / SPARE PARTS

Ø Fräser Ø Cutter	Unterlegscheibe <sup>1</sup> Shim <sup>1</sup> 	Spannschraube* Clamping screw*	Schlüssel Key 	Spannschraube <sup>1</sup> Clamping screw <sup>1</sup> 	Schraubendreher <sup>1</sup> Screwdriver <sup>1</sup> 	Spindelabdeckung <sup>2</sup> Arbor cover <sup>2</sup> 
125	SSN 150616	US 5018-T20P	SDR T20P-T	US 54511-T15P	SDR T15P-T	-
160	SSN 150616	US 5018-T20P	SDR T20P-T	US 54511-T15P	SDR T15P-T	CAC 160C
200	SSN 150616	US 5018-T20P	SDR T20P-T	US 54511-T15P	SDR T15P-T	CAC 200C
250	SSN 150616	US 5018-T20P	SDR T20P-T	US 54511-T15P	SDR T15P-T	CAC 250C
315	SSN 150616	US 5018-T20P	SDR T20P-T	US 54511-T15P	SDR T15P-T	CAC 315C

Ø Fräser Ø Cutter	Abdeckungschraube <sup>2</sup> Cover screw <sup>2</sup> 	Schlüssel <sup>2</sup> Key <sup>2</sup> 	Stecker Plug 	Sicherungsring Retaining ring 	Schraube für Messerkopf Screw for taper clamping 
125	-	-	-	-	-
160	HSD 0825C	HXK 5	-	-	-
200	HSD 1025C	HXK 7	-	-	HS 1655C
250	HSD 1025C	HXK 7	-	-	HS 1655C
315	HSD 1035C	HXK 7	CACP 3150C	RRH 34	HS 1655C



● Lagersortiment / ○ Kein Lagersortiment  
● Stocked as standard / ○ Not stocked as standard  
Derzeitiges Lagerbestandsortiment ist abhängig von der gültigen Preisliste. / See price list for current availability.

PLANFRÄSER  
FACE MILLING CUTTERS

ECKFRÄSER  
SHOULDER END MILLING CUTTERS

WALZENSTIRNFRÄSER/SCHLEIFENFRÄSER  
SQUARE SHOULDER/SLOT MILLING CUTTERS

KOPIERFRÄSER  
COPY MILLING CUTTERS

FRÄSER FÜR SPEZ. ANWENDUNGEN  
CUTTERS FOR SPECIAL APPLICATION

WENDESCHNEIDPLATTEN  
INDEXABLE INSERTS